

**MINUTES OF  
PARKS AND RECREATION MEETING  
OF THE  
BOARD OF DIRECTORS**

**March 28, 2018**

THE STATE OF TEXAS §  
COUNTY OF HARRIS §  
OAKMONT PUBLIC UTILITY DISTRICT §

The Board of Directors (the "Board") of Oakmont Public Utility District (the "District") met in regular session, open to the public, at Auburn Lakes Recreation Center, the District's designated meeting place inside the boundaries of the District, on Wednesday, March 28, 2018 at 7:00 p.m.; whereupon, the roll was called of the members of the Board, to-wit:

Ty Warren	-	President
Shaun Hebert	-	Vice President
Kerry Simmons	-	Secretary
Bruce Bramlett	-	Assistant Secretary
Jennifer Smith	-	Assistant Secretary

All members of the Board were present, except Director Bramlett, thus constituting a quorum.

Additionally, in attendance were: Bill Goudek of FINS; Tina DeAses of The Risher Companies, the District's Recreation Manager ("Risher"); and Michael Murr of Murr Incorporated, the District's Landscape Architect.

WHEREUPON, the meeting was called to order in accordance with the posted meeting notice, which is attached hereto as Exhibit "A".

**HEAR FROM FINS REPRESENTATIVE**

The Board recognized Mr. Goudek of FINS, who presented a proposal to contract with the District to provide swim lesson services. A copy of the FINS proposal is included with the Recreation Center Manager's Report attached hereto as Exhibit "B".

The Board also considered a proposal from Aquatic Management to provide swim lesson services, a copy of which is also included in the Recreation Center Manager's Report.

After discussion and review, upon a motion made by Director Warren, seconded by Director Hebert, the Board voted unanimously to accept the proposal as submitted by FINS and to authorize moving forward with establishing an agreement for the same.

## **RECEIVE GRAND SLAM PROPOSAL FOR OUTDOOR SOUND SYSTEM**

The Board tabled action on this item until such time as the landscaping is completed at the recreation center.

## **APPROVE MINUTES OF MEETING HELD FEBRUARY 28, 2018**

The Board considered the minutes of the meeting held February 28, 2018, which were distributed to the Board for review prior to the meeting. After discussion, upon a motion by Director Simmons, seconded by Director Warren, the Board voted unanimously to approve the minutes as presented.

## **HEAR FROM SILVERSAND SERVICES**

The Board next considered proposals for work to be completed by Silversand Services, which are included in the Recreation Center Manager's Report.

In regards to proposal #41754, upon a motion by Director Hebert, seconded by Director Warren, the Board voted unanimously to approve the proposal as presented, however, requested the work not be completed until after May 1<sup>st</sup>.

Regarding proposals #41855 and #3920.01, upon a motion by Director Warren, seconded by Director Smith, the Board voted unanimously to approve the proposals, as amended by comments presented, including to only complete the proposed work in Zones 2, 4, and 5 for a cost not to exceed \$8,000.

Regarding proposal #41963, upon a motion by Director Warren, seconded by Director Simmons, the Board voted unanimously to approve the proposal as presented.

Regarding proposal #42089, upon a motion by Director Hebert, seconded by Director Warren, the Board voted unanimously to approve the proposal as amended by comments presented, including reducing the price of the proposed work to not exceed \$255 and for the work to be completed before the start of swim season.

## **RECREATION CENTER MANAGER REPORT**

The Board recognized Ms. DeAses, who presented the Recreation Center Manager's Report, a copy of which is attached hereto as Exhibit "B".

Ms. DeAses presented a proposal to replace two traditional ten-gallon water heaters at the clubhouse and fitness center. After consideration and discussion, upon a motion by Director Hebert, seconded by Director Simmons, the Board voted unanimously to purchase the proposed water heaters from Evenflow Plumbing at a cost of \$1,875.00.

The Board then considered revising the quote from A+ Spring Electric previously approved to include \$147.00 in additional work to include new circuits for the fans installed. Upon a motion by Director Simmons, seconded by Director Hebert, the Board voted unanimously to approve the revised quote as presented.

Ms. DeAses then presented proposals from Aquatic Pool Management for items identified as needed. The Board reviewed the proposals, and, upon a motion by Director Hebert, seconded by Director Warren, voted unanimously to approve the proposals as presented, at a cost not to exceed \$6,000. The details of the proposals are contained in the Recreation Center Manager's Report.

The Board then considered proposals for pool deck cleaning. Ms. DeAses noted that Walt's Pools had provided a verbal quote of \$1,000 to complete the pool deck cleaning. After discussion, upon a motion by Director Hebert, seconded by Director Simmons, the Board voted unanimously to approve the quote submitted by Walt's Pools upon confirmation of the price presented and upon confirmation that the work could be completed as soon as possible.

Ms. DeAses then presented proposals for the installation of swim team flag pole holes within the pool decking. After review, upon a motion by Director Warren, seconded by Director Hebert, the Board voted unanimously to approve the proposal submitted by Houston Pool Renovations at a cost not to exceed \$1,750.

The Board then reviewed proposals relating to pool deck expansion joint projects. After full discussion and consideration, upon a motion by Director Hebert, seconded by Director Warren, the Board voted unanimously to (i) authorize grinding, sanding, re-sealing, and repainting of 450-linear feet of expansion joints and replace with slab gasket and caulking at a cost not to exceed \$6,800, and (ii) authorize the Recreation Committee to determine whether Houston Pool Renovations or Walt's Pools is to complete the work upon the submission of a proposal by Walt's Pools.

Consideration was then given to the purchase of new pool furniture. After discussion, upon a motion by Director Simmons, seconded by Director Smith, the Board voted unanimously to approve Quote #27160 from Koper Enterprises, Inc., for the purchase of pool furniture in an amount not to exceed \$10,250.

The Board then considered, and, upon a motion by Director Warren, seconded by Director Smith, voted unanimously to authorize the purchase of pool signs from Value Print and Ship Harmony.

Ms. DeAses then presented a proposal to purchase new fitness center equipment, including heavier dumbbells, and a Concept2 erg. After discussion upon a motion by Director Warren, seconded by Director Smith, the Board voted unanimously to purchase the equipment presented at a cost of \$1,830.53.

No other action was taken on any of the other proposals presented or included in the Recreation Center Manager's Report.

After full review of the report, upon a motion by Director Simmons seconded by Director Smith, the Board voted unanimously to approve the Recreation Center Manager's Report.

**RATIFY ACTIONS TAKEN AT PREVIOUS RECREATION MEETING**

Upon a motion by Director Warren, seconded by Director Simmons, the Board voted unanimously to ratify the action taken to authorize use of the pool by the Auburn Lakes Swim Team.

Upon a motion by Director Warren, seconded by Director Hebert, the Board voted unanimously to ratify the action taken to authorize the purchase of pool equipment for the swim team's use at the pool.

Upon a motion by Director Warren, seconded by Director Smith, the Board voted unanimously to ratify the action taken to concur with the swim team registration fees established.

**LANDSCAPE ARCHITECT REPORT**

The Board then recognized Mr. Murr, who presented the Landscape Architect's Report, a copy of which is attached hereto as Exhibit "C".

Mr. Murr reviewed several proposals for completion of work throughout the District, including installing shade structures at the playground, installing softscape and hardscape at the pool area, and a concrete pour at the recreation center.

After review of the report and discussion, upon a motion made by Director Warren, seconded by Director Simmons, the Board voted unanimously to (i) approve the Landscape Architect's Report, and (ii) authorize Mr. Murr to proceed with the work discussed at an amount not to exceed \$60,000.

**HEAR FROM RECREATION COMMITTEE**

No action was taken on this matter.

**HEAR DIRECTOR REPORTS**

No Director reports were presented.

**HEAR FROM THE PUBLIC**

No comments were presented.

There being no other business to come before the Board, the meeting was adjourned.

[REMAINDER OF PAGE LEFT INTENTIONALLY BLANK]

PASSED, APPROVED and ADOPTED this April 25, 2018.

(DISTRICT SEAL)



*Kerry Sumner*  
Secretary, Board of Directors

**AMENDED  
OAKMONT PUBLIC UTILITY DISTRICT  
NOTICE OF MEETING  
PARKS AND RECREATION**

Notice is hereby given pursuant to V.T.C.A., Government Code, Chapter 551, that the Board of Directors of Oakmont Public Utility District will meet in **regular** session, open to the public, at **7:00 p.m.**, on **Wednesday, March 28, 2018**, at the **Auburn Lakes Recreation Center**, a meeting location inside the District, at which meeting the following items will be considered:

1. Approve minutes from February 28, 2018 meeting.
2. Hear from Fins representative regarding swim lessons and consider authorizing and/or entering into an agreement for same.
3. Hear from Grand Slam representative and receive proposal for sound system at recreation center, and consider authorizing purchase and installation of same.
4. Hear Engineer's Report and consider acting thereon, including:
  - a. Authorize Engineer to proceed with inspection of plaster at beach entry;
  - b. Approve proposal for repair of slab gasket and cool decking; and
  - c. Authorize Engineer to proceed with projects as directed.
5. Hear report from Landscape Architect and consider acting thereon, including:
  - a. Receive proposals for installation of landscaping throughout District and consider authorizing same;
  - b. Receive proposals for installation of concrete slab at pavilion and consider authorizing same; and
  - c. Authorize Landscape Architect to proceed with park projects as directed.
6. Hear report from Recreation Center Manager, and consider acting thereon, including:
  - a. Review and consider approving proposals for purchase of recreation equipment, repairs to facilities, and/or authorizing camps and activities;
  - b. Consider authorizing Recreation Center Manager to proceed with projects, purchases, and repairs as directed by the Board; and
  - c. Ratify action taken to (i) authorize swim team use of the pool, (ii) approve purchase of swim team equipment, and (iii) establish registration fees for in-district and out-of-district swim team participants.
7. Hear from Silversand Services and consider authorizing proposals for landscaping maintenance.
8. Hear from Recreation Committee, and consider taking action, including:
  - a. Ratify action taken by Recreation Committee during the previous month to purchase equipment or approve repairs, as necessary.
9. Hear Directors reports, and consider taking action thereon.
10. Hear from the public.

Pursuant to V.T.C.A. Government Code, Chapter 551, the Board of Directors may convene in closed session in relation to any agenda item included in this Notice, such closed session will be held at the date, hour and place given in this Notice concerning any all subjects for any and all purposes permitted by V.T.C.A. Government Code, Chapter 551, including but not limited to pending or contemplated litigation, security matters and devices, personnel matters, real estate transactions or a private consultation with the attorney for the District on any or all subjects or matters authorized by law.

EXECUTED this 23rd day of March, 2018.

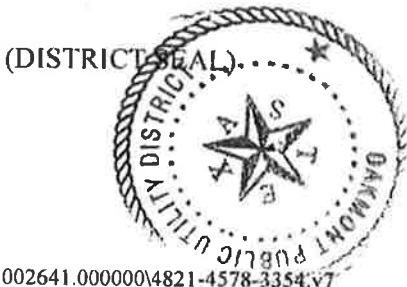

OAKMONT PUBLIC UTILITY DISTRICT

By Mallory J. Craig

Mallory J. Craig  
Coats Rose, P.C.

Attorneys for the District



**OAKMONT PUBLIC UTILITY DISTRICT  
NOTICE OF MEETING  
PARKS AND RECREATION**

Notice is hereby given pursuant to V.T.C.A., Government Code, Chapter 551, that the Board of Directors of Oakmont Public Utility District will meet in **regular** session, open to the public, at **7:00 p.m.**, on **Wednesday, March 28, 2018**, at the **Auburn Lakes Recreation Center**, a meeting location inside the District, at which meeting the following items will be considered:

1. Approve minutes from February 28, 2018 meeting.
2. Hear from Fins representative regarding swim lessons and consider authorizing and/or entering into an agreement for same.
3. Hear from Grand Slam representative and receive proposal for sound system at recreation center, and consider authorizing purchase and installation of same.
4. Hear Engineer's Report and consider acting thereon, including:
  - a. Authorize Engineer to proceed with inspection of plaster at beach entry;
  - b. Approve proposal for repair of slab gasket and cool decking; and
  - c. Authorize Engineer to proceed with projects as directed.
5. Hear from Recreation Committee, and consider taking action.
6. Hear report from Landscape Architect and consider acting thereon, including:
  - a. Receive proposals for installation of landscaping throughout District and consider authorizing same;
  - b. Receive proposals for installation of concrete slab at pavilion and consider authorizing same; and
  - c. Authorize Landscape Architect to proceed with park projects as directed.
7. Hear report from Recreation Center Manager, and consider acting thereon, including:
  - a. Review and consider approving proposals for purchase of recreation equipment, repairs to facilities, and/or authorizing camps and activities; and
  - b. Consider authorizing Recreation Center Manager to proceed with projects, purchases, and repairs as directed by the Board.
8. Hear from Silversand Services and consider authorizing proposals for landscaping maintenance.
9. Hear Directors reports, and consider taking action thereon.
10. Hear from the public.

Pursuant to V.T.C.A. Government Code, Chapter 551, the Board of Directors may convene in closed session in relation to any agenda item included in this Notice, such closed session will be held at the date, hour and place given in this Notice concerning any all subjects for any and all purposes permitted by V.T.C.A. Government Code, Chapter 551, including but not limited to pending or contemplated litigation, security matters and devices, personnel matters, real estate transactions or a private consultation with the attorney for the District on any or all subjects or matters authorized by law.

EXECUTED this 22nd day of March, 2018.

(DISTRICT SEAL)



OAKMONT PUBLIC UTILITY DISTRICT

By: Mallory J. Craig

Mallory J. Craig  
Coats Rose, P.C.  
Attorneys for the District

CERTIFICATE OF POSTING OF NOTICE OF MEETING

THE STATE OF TEXAS §  
COUNTY OF HARRIS §  
OAKMONT PUBLIC UTILITY DISTRICT §

I, Janice Woodburn, the undersigned, hereby state that I posted the attached Notice of Meeting of the Board of Directors of Oakmont Public Utility District at the administrative office of the District, 9 Greenway Plaza, Suite 1100, Houston, Texas, on Thursday, March 22, 2018, at 2:30 p.m., which time was not less than 72 hours prior to the scheduled time of the meeting.

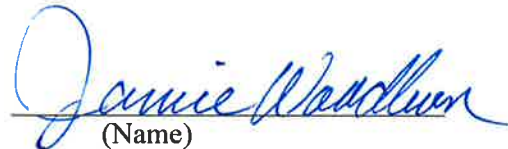
  
(Name)



**OAKMONT PUBLIC UTILITY DISTRICT  
NOTICE OF MEETING  
PARKS AND RECREATION**

Notice is hereby given pursuant to V.T.C.A., Government Code, Chapter 551, that the Board of Directors of Oakmont Public Utility District will meet in **regular** session, open to the public, at **7:00 p.m.**, on **Wednesday, March 28, 2018**, at the **Auburn Lakes Recreation Center**, a meeting location inside the District, at which meeting the following items will be considered:

1. Approve minutes from February 28, 2018 meeting.
2. Hear from Fins representative regarding swim lessons and consider authorizing and/or entering into an agreement for same.
3. Hear from Grand Slam representative and receive proposal for sound system at recreation center, and consider authorizing purchase and installation of same.
4. Hear Engineer's Report and consider acting thereon, including:
  - a. Authorize Engineer to proceed with inspection of plaster at beach entry;
  - b. Approve proposal for repair of slab gasket and cool decking; and
  - c. Authorize Engineer to proceed with projects as directed.
5. Hear from Recreation Committee, and consider taking action.
6. Hear report from Landscape Architect and consider acting thereon, including:
  - a. Receive proposals for installation of landscaping throughout District and consider authorizing same;
  - b. Receive proposals for installation of concrete slab at pavilion and consider authorizing same; and
  - c. Authorize Landscape Architect to proceed with park projects as directed.
7. Hear report from Recreation Center Manager, and consider acting thereon, including:
  - a. Review and consider approving proposals for purchase of recreation equipment, repairs to facilities, and/or authorizing camps and activities; and
  - b. Consider authorizing Recreation Center Manager to proceed with projects, purchases, and repairs as directed by the Board.
8. Hear from Silversand Services and consider authorizing proposals for landscaping maintenance.
9. Hear Directors reports, and consider taking action thereon.
10. Hear from the public.

Pursuant to V.T.C.A. Government Code, Chapter 551, the Board of Directors may convene in closed session in relation to any agenda item included in this Notice, such closed session will be held at the date, hour and place given in this Notice concerning any all subjects for any and all purposes permitted by V.T.C.A. Government Code, Chapter 551, including but not limited to pending or contemplated litigation, security matters and devices, personnel matters, real estate transactions or a private consultation with the attorney for the District on any or all subjects or matters authorized by law.

EXECUTED this 22nd day of March, 2018.

(DISTRICT SEAL)



OAKMONT PUBLIC UTILITY DISTRICT

By: Mallory J. Craig  
Mallory J. Craig  
Coats Rose, P.C.  
Attorneys for the District

DO NOT DETACH

CERTIFICATE OF POSTING OF NOTICE OF MEETING

THE STATE OF TEXAS §  
COUNTY OF HARRIS §  
OAKMONT PUBLIC UTILITY DISTRICT §

I, TINA DEASES, the undersigned, hereby state that I posted a copy of the attached Notice of Meeting of the Board of Directors of Oakmont Public Utility District at 25005 Northcrest Drive, Spring, Texas, the location inside the boundaries of the District designated for the posting of agendas, on the 23<sup>RD</sup> day of MARCH, 2018, at 11:47AM, which time was not less than 72 hours prior to the scheduled time of the special meeting.

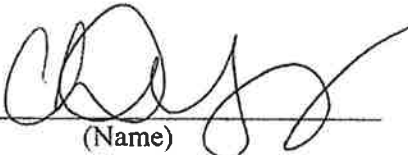
  
(Name)

4811-0138-0114, v. 1

CERTIFICATE OF POSTING OF NOTICE OF MEETING

THE STATE OF TEXAS §  
COUNTY OF HARRIS §  
OAKMONT PUBLIC UTILITY DISTRICT §

I, Janice Woodburn, the undersigned, hereby state that I posted the attached Notice of Meeting of the Board of Directors of Oakmont Public Utility District at the administrative office of the District, 9 Greenway Plaza, Suite 1100, Houston, Texas, on Friday, March 23, 2018, at 12:30 p.m., which time was not less than 72 hours prior to the scheduled time of the meeting.

  
\_\_\_\_\_  
(Name)

**AMENDED  
OAKMONT PUBLIC UTILITY DISTRICT  
NOTICE OF MEETING  
PARKS AND RECREATION**

Notice is hereby given pursuant to V.T.C.A., Government Code, Chapter 551, that the Board of Directors of Oakmont Public Utility District will meet in **regular** session, open to the public, at **7:00 p.m.**, on **Wednesday, March 28, 2018**, at the **Auburn Lakes Recreation Center**, a meeting location inside the District, at which meeting the following items will be considered:

1. Approve minutes from February 28, 2018 meeting.
2. Hear from Fins representative regarding swim lessons and consider authorizing and/or entering into an agreement for same.
3. Hear from Grand Slam representative and receive proposal for sound system at recreation center, and consider authorizing purchase and installation of same.
4. Hear Engineer's Report and consider acting thereon, including:
  - a. Authorize Engineer to proceed with inspection of plaster at beach entry;
  - b. Approve proposal for repair of slab gasket and cool decking; and
  - c. Authorize Engineer to proceed with projects as directed.
5. Hear report from Landscape Architect and consider acting thereon, including:
  - a. Receive proposals for installation of landscaping throughout District and consider authorizing same;
  - b. Receive proposals for installation of concrete slab at pavilion and consider authorizing same; and
  - c. Authorize Landscape Architect to proceed with park projects as directed.
6. Hear report from Recreation Center Manager, and consider acting thereon, including:
  - a. Review and consider approving proposals for purchase of recreation equipment, repairs to facilities, and/or authorizing camps and activities;
  - b. Consider authorizing Recreation Center Manager to proceed with projects, purchases, and repairs as directed by the Board; and
  - c. Ratify action taken to (i) authorize swim team use of the pool, (ii) approve purchase of swim team equipment, and (iii) establish registration fees for in-district and out-of-district swim team participants.
7. Hear from Silversand Services and consider authorizing proposals for landscaping maintenance.
8. Hear from Recreation Committee, and consider taking action, including:
  - a. Ratify action taken by Recreation Committee during the previous month to purchase equipment or approve repairs, as necessary.
9. Hear Directors reports, and consider taking action thereon.
10. Hear from the public.

Pursuant to V.T.C.A. Government Code, Chapter 551, the Board of Directors may convene in closed session in relation to any agenda item included in this Notice, such closed session will be held at the date, hour and place given in this Notice concerning any all subjects for any and all purposes permitted by V.T.C.A. Government Code, Chapter 551, including but not limited to pending or contemplated litigation, security matters and devices, personnel matters, real estate transactions or a private consultation with the attorney for the District on any or all subjects or matters authorized by law.

EXECUTED this 23rd day of March, 2018.



OAKMONT PUBLIC UTILITY DISTRICT

By Mallory J. Craig  
Mallory J. Craig  
Coats Rose, P.C.  
Attorneys for the District

**AMENDED  
OAKMONT PUBLIC UTILITY DISTRICT  
NOTICE OF MEETING  
PARKS AND RECREATION**

Notice is hereby given pursuant to V.T.C.A., Government Code, Chapter 551, that the Board of Directors of Oakmont Public Utility District will meet in **regular** session, open to the public, at **7:00 p.m.**, on **Wednesday, March 28, 2018**, at the **Auburn Lakes Recreation Center**, a meeting location inside the District, at which meeting the following items will be considered:

1. Approve minutes from February 28, 2018 meeting.
2. Hear from Fins representative regarding swim lessons and consider authorizing and/or entering into an agreement for same.
3. Hear from Grand Slam representative and receive proposal for sound system at recreation center, and consider authorizing purchase and installation of same.
4. Hear Engineer's Report and consider acting thereon, including:
  - a. Authorize Engineer to proceed with inspection of plaster at beach entry;
  - b. Approve proposal for repair of slab gasket and cool decking; and
  - c. Authorize Engineer to proceed with projects as directed.
5. Hear report from Landscape Architect and consider acting thereon, including:
  - a. Receive proposals for installation of landscaping throughout District and consider authorizing same;
  - b. Receive proposals for installation of concrete slab at pavilion and consider authorizing same; and
  - c. Authorize Landscape Architect to proceed with park projects as directed.
6. Hear report from Recreation Center Manager, and consider acting thereon, including:
  - a. Review and consider approving proposals for purchase of recreation equipment, repairs to facilities, and/or authorizing camps and activities;
  - b. Consider authorizing Recreation Center Manager to proceed with projects, purchases, and repairs as directed by the Board; and
  - c. Ratify action taken to (i) authorize swim team use of the pool, (ii) approve purchase of swim team equipment, and (iii) establish registration fees for in-district and out-of-district swim team participants.
7. Hear from Silversand Services and consider authorizing proposals for landscaping maintenance.
8. Hear from Recreation Committee, and consider taking action, including:
  - a. Ratify action taken by Recreation Committee during the previous month to purchase equipment or approve repairs, as necessary.
9. Hear Directors reports, and consider taking action thereon.
10. Hear from the public.

Pursuant to V.T.C.A. Government Code, Chapter 551, the Board of Directors may convene in closed session in relation to any agenda item included in this Notice, such closed session will be held at the date, hour and place given in this Notice concerning any all subjects for any and all purposes permitted by V.T.C.A. Government Code, Chapter 551, including but not limited to pending or contemplated litigation, security matters and devices, personnel matters, real estate transactions or a private consultation with the attorney for the District on any or all subjects or matters authorized by law.

EXECUTED this 23rd day of March, 2018.

(DISTRICT SEAL)



OAKMONT PUBLIC UTILITY DISTRICT

By Mallory J. Craig  
Mallory J. Craig  
Coats Rose, P.C.  
Attorneys for the District

MPR  
9:00  
MD

OR

**OAKMONT PUBLIC UTILITY DISTRICT  
NOTICE OF MEETING  
PARKS AND RECREATION**

1306701  
03/22/2018 PERSONAL  
\$9.00 MPR - NOTICE MTG

Notice is hereby given pursuant to V.T.C.A., Government Code, Chapter 551, that the Board of Directors of Oakmont Public Utility District will meet in **regular session**, open to the public, at **7:00 p.m.**, on **Wednesday, March 28, 2018**, at the **Auburn Lakes Recreation Center**, a meeting location inside the District, at which meeting the following items will be considered:

1. Approve minutes from February 28, 2018 meeting.
2. Hear from Fins representative regarding swim lessons and consider authorizing and/or entering into an agreement for same.
3. Hear from Grand Slam representative and receive proposal for sound system at recreation center, and consider authorizing purchase and installation of same.
4. Hear Engineer's Report and consider acting thereon, including:
  - a. Authorize Engineer to proceed with inspection of plaster at beach entry;
  - b. Approve proposal for repair of slab gasket and cool decking; and
  - c. Authorize Engineer to proceed with projects as directed.
5. Hear from Recreation Committee, and consider taking action.
6. Hear report from Landscape Architect and consider acting thereon, including:
  - a. Receive proposals for installation of landscaping throughout District and consider authorizing same;
  - b. Receive proposals for installation of concrete slab at pavilion and consider authorizing same; and
  - c. Authorize Landscape Architect to proceed with park projects as directed.
7. Hear report from Recreation Center Manager, and consider acting thereon, including:
  - a. Review and consider approving proposals for purchase of recreation equipment, repairs to facilities, and/or authorizing camps and activities; and
  - b. Consider authorizing Recreation Center Manager to proceed with projects, purchases, and repairs as directed by the Board.
8. Hear from Silversand Services and consider authorizing proposals for landscaping maintenance.
9. Hear Directors reports, and consider taking action thereon.
10. Hear from the public.

Pursuant to V.T.C.A. Government Code, Chapter 551, the Board of Directors may convene in closed session in relation to any agenda item included in this Notice, such closed session will be held at the date, hour and place given in this Notice concerning any all subjects for any and all purposes permitted by V.T.C.A. Government Code, Chapter 551, including but not limited to pending or contemplated litigation, security matters and devices, personnel matters, real estate transactions or a private consultation with the attorney for the District on any or all subjects or matters authorized by law.

EXECUTED this 22nd day of March, 2018.

(DISTRICT SEAL)



OAKMONT PUBLIC UTILITY DISTRICT

By: Mallory J. Craig  
Mallory J. Craig  
Coats Rose, P.C.  
Attorneys for the District

Steph...  
COUNTY CLERK  
HARRIS COUNTY TEXAS

2018 MAR 22 AM 10:16

FILED

DO NOT DETACH

CERTIFICATE OF POSTING OF NOTICE OF MEETING

THE STATE OF TEXAS §  
COUNTY OF HARRIS §  
OAKMONT PUBLIC UTILITY DISTRICT §

I, TINA DEASES, the undersigned, hereby state that I posted a copy of the attached Notice of Meeting of the Board of Directors of Oakmont Public Utility District at 25005 Northcrest Drive, Spring, Texas, the location inside the boundaries of the District designated for the posting of agendas, on the 22ND day of MARCH, 2010, at 1247PM, which time was not less than 72 hours prior to the scheduled time of the special meeting.

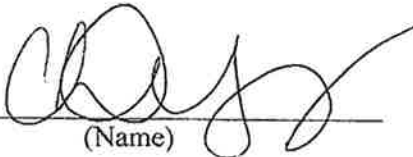
  
(Name)

4811-0138-0114, v. 1

1307081  
03/23/2018 PERSONAL  
\$9.00 MPR - NOTICE MTG

*gr* **AMENDED  
OAKMONT PUBLIC UTILITY DISTRICT  
NOTICE OF MEETING  
PARKS AND RECREATION**

Notice is hereby given pursuant to V.T.C.A., Government Code, Chapter 551, that the Board of Directors of Oakmont Public Utility District will meet in **regular** session, open to the public, at **7:00 p.m.**, on **Wednesday, March 28, 2018**, at the **Auburn Lakes Recreation Center**, a meeting location inside the District, at which meeting the following items will be considered:

1. Approve minutes from February 28, 2018 meeting.
2. Hear from Fins representative regarding swim lessons and consider authorizing and/or entering into an agreement for same.
3. Hear from Grand Slam representative and receive proposal for sound system at recreation center, and consider authorizing purchase and installation of same.
4. Hear Engineer's Report and consider acting thereon, including:
  - a. Authorize Engineer to proceed with inspection of plaster at beach entry;
  - b. Approve proposal for repair of slab gasket and cool decking; and
  - c. Authorize Engineer to proceed with projects as directed.
5. Hear report from Landscape Architect and consider acting thereon, including:
  - a. Receive proposals for installation of landscaping throughout District and consider authorizing same;
  - b. Receive proposals for installation of concrete slab at pavilion and consider authorizing same; and
  - c. Authorize Landscape Architect to proceed with park projects as directed.
6. Hear report from Recreation Center Manager, and consider acting thereon, including:
  - a. Review and consider approving proposals for purchase of recreation equipment, repairs to facilities, and/or authorizing camps and activities;
  - b. Consider authorizing Recreation Center Manager to proceed with projects, purchases, and repairs as directed by the Board; and
  - c. Ratify action taken to (i) authorize swim team use of the pool, (ii) approve purchase of swim team equipment, and (iii) establish registration fees for in-district and out-of-district swim team participants.
7. Hear from Silversand Services and consider authorizing proposals for landscaping maintenance.
8. Hear from Recreation Committee, and consider taking action, including:
  - a. Ratify action taken by Recreation Committee during the previous month to purchase equipment or approve repairs, as necessary.
9. Hear Directors reports, and consider taking action thereon.
10. Hear from the public.

Pursuant to V.T.C.A. Government Code, Chapter 551, the Board of Directors may convene in closed session in relation to any agenda item included in this Notice, such closed session will be held at the date, hour and place given in this Notice concerning any all subjects for any and all purposes permitted by V.T.C.A. Government Code, Chapter 551, including but not limited to pending or contemplated litigation, security matters and devices, personnel matters, real estate transactions or a private consultation with the attorney for the District on any or all subjects or matters authorized by law.

EXECUTED this 23rd day of March, 2018.

(DISTRICT SEAL)

OAKMONT PUBLIC UTILITY DISTRICT

By Mallory J. Craig  
Mallory J. Craig  
Coats Rose, P.C.  
Attorneys for the District

*S. St...*  
HARRIS COUNTY, TEXAS  
CLERK  
*...*

2018 MAR 23 PM 12:31

FILED



Auburn Lakes Recreation Center:  
Oakmont Public Utility District  
Monthly Report – March 2018



**RISHER FITNESS MANAGEMENT**

Prepared by: Tina DeAses, Recreation Director  
Risher Fitness Management, Inc.

Risher Fitness Management, Inc. has been contracted to manage the Auburn Lakes Recreation Center.

**Auburn Lakes Recreation Center and Risher Fitness Management  
Mission Statement**

Our mission here at Risher Fitness Management is to provide safe and fun recreation, fitness, special events, and wellness opportunities for all residents. We strive to promote and enhance healthy lifestyles and well-being in a welcoming environment for both children and adults alike. Providing a clean, fun, and quality experience in every one of the recreation centers we manage with qualified and certified employees. We aim to offer you with the best and most positive environment you will find in any community recreational setting. Through quality customer service and community activities we hope to bring each community closer together.

**Employees**

The employees at the Auburn Lakes Recreation Center working under Risher Fitness Management, Inc. (RFM) for the month included:

- Management Team:
  - o Tina DeAses, Jenifer Cox
- Fitness Room Attendants:
  - o Angelica Antonello, Keaton Ball, Alex Fontana, Javi Solano

**Fitness Center**

	2/24 - 3/21
Total Entrees	1,325
Fitness Center Orientations	2

**Clubhouse**

Group Fitness Classes	PiYo, HIIT it, Boot Camp
Resident Reservations	1
Healthy Living Presentation- Learn to Eat	9

**Pool**

Pool will re-open in April 2018 for swim team, May 2018 for Auburn Lakes open swim.

**Monthly Expenses 2/24-3/21:**

Company	Invoice/Service	Cost
Vanguard	Cleaning all areas 1/ week (pool pavilion included)	\$391.00
AT & T phone	Land line	\$65.12
AT&T internet	Internet	\$55.46
Direct TV	Clubhouse TV	\$54.24
Ready Refresh	Water service	\$31.90
Comcast	Cable service for Fitness Center	\$177.98

①

②

	Paid by Bookkeeper	\$775.70
Supplies & vendors	<b>Total Paid by Risher</b>	<b>\$1,649.90</b>
	<b>Grand Total</b>	<b>\$2,425.60</b>

**Monthly Income**

Monthly Income Source	\$ Amount	YTD Oct - March
Pool Passes	\$450.00	\$450.00
Clubhouse Rental Income (Feb 24 - March 21)	\$450.00	\$5,425.00
Rec Pass	\$30.00	\$315.00
<b>Total</b>	<b>\$930.00</b>	<b>\$6,190.00</b>

**Discussion Items & Quotes**

**I. Swim Lesson Provider Options**

- A. Neighborhood Swim Lessons, LLC. (aka Fins)  
Offers private 20-minute sessions with swim instructors
- B. Aquatic Management of Houston  
Offers private and semi-private lessons with lifeguards

**II. Pool Sound System**

- A. Grand Slam Audio Visual Quote #333 \$8,659.80  
Pool Pavilion Sound System includes 6 mushroom speakers, 4 speakers with 6 in woofers, amp, 8 input mixer, handheld mic, wall mount & surge protector, speaker cords

**III. Landscaping projects at Auburn Lakes Rec Center and ponds - Silversand Services**

- A. Estimate ID: 41754 \$3,800.00  
Proposal to top dress the granite gravel at the west and east detention ponds to fix low and washed out areas only.
- B. Estimate ID: 41855 \$29,497.50  
Proposal to add sod for bare and thin areas around the recreation center property. Areas will be identified on a map. (Broken into 5 sections)
- C. Estimate ID: 3920.01 \$1,200.00  
Proposal to add sprays zone at area that don't have irrigation.
- D. Estimate ID: 41906 \$140.00  
Conversion of all controllers to Smartline controllers. Includes all equipment, weather station, installation and programming. Does not include battery operated Unik controllers.

③

- E. Estimate ID: 41963 \$222.50  
Addition of asian jasmine to fill in bare areas and damage in the bed on circle island median front of clubhouse.
- F. Estimate ID: 42089 \$700 (\$140-175/month)  
install Advion granular ant bait treatment to all landscape areas for the pool/recreation center property. This product has a 4-5 month control.

**IV. Water heater replacement**

- A. Option 1: Replace two traditional ten-gallon water heaters, one in the clubhouse and one in fitness center
  1. Evenflow Plumbing Pricing \$1,875.00  
Includes labor, equipment, installation, hauling away trash
- B. Option2: Install under the counter insta-hot heaters (5 total, 2 in clubhouse, 2 in fitness center, 1 in outdoor restroom) \$6041.00
  1. Evenflow Plumbing Pricing \$2,200.00  
Includes labor, equipment, installation, hauling away trash
  2. A+ Electric \$3,841.00  
Includes labor, wires, circuits for "Instant hot" water heaters

**V. Fans at pool party area**

- A. A+ Spring Electric quote 180308
  1. Revised quote for additional work \$437.00

Last month the Oakmont PUD Board of Directors approved \$290.00 for work but that didn't include running new circuits for the fans. The new total is an increase of \$147.00.

**VI. Swimming Pool Projects**

- A. Aquatic Pool Management walk through found the following items needed to be addressed as quickly as possible so the Oakmont PUD pool would be in compliance with Texas swimming pool codes, improve safety and to help with water flow. \$5,973.60
  1. Quote 1 \$5,583.00  
4-500 watt LED, 2 spa LED, repair junction box
  2. Quote 2 \$30.12 (\$15.06 x 2)  
Add ganges to main pipe shut off and 1 other pipe
  3. Quote 3 \$42.35  
Replace 1 skimmer basket
  4. Quote 4 \$200.55 (\$66.85 x 3)  
Replace 3 rescue tubes
  5. Quote 5 \$54.46 (\$27.23 x 2)  
No Diving Signs
  6. Quote 6 \$63.12 (\$7.89 x 8)  
Pool outlet covers



④

- B. Pool Deck Cleaning
1. Houston Pool Renovations \$3,250.00  
Pressure wash entire deck 10,300 sq feet and use a diluted muriatic acid solution to help remove scale and calcium deposits so the deck can look a uniform as possible.
  2. Malibu Pools \$760.00  
Power washing entire pool deck and use muriatic acid solution to clean the white marks left on the deck.
- C. Swimming Team Flag Pole Holes
1. Cut 6 holes in deck for swim team poles, 4 for backstroke poles, 2 false start poles
    - a. Houston Pool Renovations \$1,750.00
    - b. Malibu Pools waiting on quote
    - c. Greater Houston \$1,820.00
- D. Pool Deck Expansion Joint Projects
1. Remove material from all 2,500 linear feet of expansion joints and replace with new self-leveling caulk
    - a. Houston Pool Renovations \$17,500.00
    - b. Malibu Pools \$14,375.00
  2. Grinding, sanding, re-sealing, and repainting all 2,500 linear feet of expansion joints and replace with slab gasket & caulk edges
    - a. Houston Pool Renovations \$35,000.00
    - b. Malibu Pools \$18,125.00
    - c. Cody Pools Waiting
  3. Removing material from approximately 450 linear feet of expansion joints & re-sealing and replacing with new caulk
    - a. Houston Pool Renovations \$3,600.00
    - b. Malibu Pools \$2,512.75
  4. Grinding, sanding, re-sealing, and repainting all 450 linear feet of expansion joints and replace with slab gasket & caulk edges
    - a. Houston Pool Renovations \$6,800.00
    - b. Malibu Pools \$3,168.25
    - c. Cody Pools Waiting
- E. Pool Furniture Project – Replace remaining white plastic furniture with same furniture as last year, Koper Enterprises, Inc
1. Quote 27160 \$10,233.71  
2 couches, 3 tables, 3 umbrellas, 3 bases, 12 chairs, shipping and assembly

5

2. Quote 27162 \$13,106.21  
2 couches, 5 tables, 5 umbrellas, 5 bases, 20 chairs, shipping and assembly
- VII. Gordon Safe & Lock \$500.00 / year  
A. Software maintenance agreement for a system with up to 16 doors / access points costs. It includes monthly bug fixes, security patches, and feature updates.
- VIII. Swimming Pool Signs  
A. Swim meet & Swimming pool signage  
15 realtor signs with frames, 18 x 24 laminated single sided sides, 2 stickers, 2 laminated posters
  1. Precision Design Signs - \$532.50
  2. Value Print and Ship Harmony- \$417.50
- IX. New Fitness Center Equipment Requests  
A. Troy Rubber Encased Dumbbells, 85 lbs & 95 lbs, TKO Vertical Dumbbell Rack, Concept Rower, Shipping & Installation \$1,830.53
- X. Ant Treatment of Pool Area & Playground  
A. Morris Pest Control (typically sprayed quarterly) (\$85/month)  
Pool Area \$130.00  
Playground \$125.00
- XI. Upcoming Risher Programs  
A. Free Meditation Seminar – April  
B. Healthy Living Presentation – May TBD
- XII. LED light nights at Rec Center Property  
A. Easter pastel colors – April 1

Maintenance Repairs Completed since Feb 23

1) Silversand Services

- Completed services on Maintenance crew service dates: 2/08/18 & 2/22/18
  - i. Services done on each of these dates: Mow as needed due to time of year, edge, monofilament trim, manual weed removal, spray lines (herbicide for weeds in hardscape & bed areas), spot treat ant piles, and debris removal. Edge, treat weeds with herbicide and blow walking trails around retention ponds. Blowing, raking and removal of leaves throughout the property. Remove trash bags from cans and add new liners. Clean and replace bags at dog waste stations. Continue checking for low limbs on trees at recreation center and retention ponds and remove as needed. Continue checking tree staking that is broken or not needed on trees and remove as needed.
  - b. Installed irrigation drain & rocks to prevent clogs at front corner of clubhouse.

6

- c. Removed damaged steel edging near Northcrest.
- d. Installed rocks around drain near the pool deck.
- c. Extended flower bed in front of clubhouse.

2) Thomas Glen Construction

- a. Repaired water damage at clubhouse kitchen ceiling, textured, and painted
- b. Repair pool pavilion – vented soffit outside and hardy-plank / ceiling inside HOA storage
- c. Stone cap repair at west pond

3) Tes-Ace Inspect

- a. Completed 8 hours of general handyman duties including: installed chair storage rack, tightened bolt at playground, adjusted door closers, emptied gutters at clubhouse and fitness center.

4) Key Lighting Concepts/ Prestige Security Services

- a. Replaced Oelo Controller box located at pool pavilion.

Maintenance Items

- 1) Submitted to Jones & Carter
  - a. Cracks in weight room ceiling, hallway, crown molding, cardio room – putting on 1-year warranty list
- 2) Submitted to Silversand
  - a. Dog waste stations bags need to be refilled at West Pond
- 3) A/C Repair company going out of business. Will find new company to perform necessary checks on the A/C units.

Updated as of 3.27.2018

7



Feb 27, 2018

To: Oakmont Public Utility District  
Board of Directors  
Tina Risher

Re: Swim Lessons – Auburn Lakes Swimming Pool, Spring, TX

Thank you for the opportunity to present the following proposal to the Board of Directors of the Oakmont Public Utility District. The purpose of this proposal is to present our session outline, pricing schedule, and policy details.

**NSL - Sessions and Pricing**

SESSION #	DATE	# OF LESSONS PER SESSION	PRICE	GENERAL NOTES
1	6/4-15	7	\$210	20 Min Private Lessons, WK 1: Tue – Friday, WK 2: Tue-Thu with weather make-up lesson on last Friday of session
2	6/18-29	7	\$210	20 Min Private Lessons, WK 1: Tue – Friday, WK 2: Tue-Thu with weather make-up lesson on last Friday of session
3	7/2-13	7	\$210	20 Min Private Lessons, WK 1: Tue – Friday, WK 2: Tue-Thu with weather make-up lesson on last Friday of session
4	7/16-27	7	\$210	20 Min Private Lessons, WK 1: Tue – Friday, WK 2: Tue-Thu with weather make-up lesson on last Friday of session
5	7/30-8/16	11	\$240	20 Min Private Lessons, WK 1 & 2: Tue – Friday, WK 3: Tue-Thu. No weather make-up for session 5 due to week 3 lessons at no chg

**LESSON TIMES:**

Morning	Afternoon/Evening
9:00-9:20	5:00-5:20
9:30-9:50	5:30-5:50
10:00-10:20	6:00-6:20
10:30-10:50	6:00-6:50
11:00-11:20	7:00-7:20
11:30-11:50	7:30-7:50

**Aquatic Management Swim Lessons Proposal**

Our swim lessons are private (1 student) or semi-private (two students) only because through years of experience group lessons do not provide enough one on one attention in 30 mins lesson time. They can be booked on-line ONCE an instructor has been secured. They are \$40 and \$50 respectively for a 30-min lesson.

The only thing we ask is that the lessons are held outside regular Lifeguarded hours and that the instructor or swim team have their own liability coverage on the teachers. This covers the PUD.

- \* SESSIONS 1-4 - TWO WEEK SESSIONS (7 lessons + weather make-up day allotted)
  - o WEEK 1 OF EACH SESSION 4 LESSONS
  - o WEEK 2 OF EACH SESSION 3 LESSONS
  - o LAST FRI OF EACH SESSION IS DESIGNATED AS WEATHER MAKE-UP DAY (IF REQUIRED)
- \* SESSION 5 - ONE THREE WEEK SESSION (11 lessons + final 3 at no charge, (no weather make-up day allotted)
  - o WEEK 1 & 2 – 4 LESSONS
  - o WEEK 3 – 3 LESSONS
  - o NO CHARGE FOR FINAL 3 LESSONS (WK 3)
  - o NO WEATHER MAKE-UP DAY OFFERED
- \* DISCOUNT
  - o SIBLING DISCOUNTS AVAILABLE
    - \$20 SESSION DISCOUNT FOR EACH ADDITIONAL SIBLING ENROLLED

Fun IN Swimming, Inc. proposes to pay Oakmont PUD or Auburn Lakes HOA a total of two dollars (\$2) for each of our paid lessons. Payments to be submitted within one week following the end of each session. Payment location TBD

Fun IN Swimming, Inc is a swim lessons company with four indoor facilities located in Spring, The Woodlands, Atascocita, and Cypress. FINS has been serving the North Houston area swim lessons needs since 1998. With over 100 employees serving the swim instruction needs of thousands of customers, FINS has gained a reputation for its expertise in teaching its students how to swim and love water activities. Our award-winning curriculum and expertly trained teachers produce safer swimmers which has always been our number one goal at FINS.

We will conduct our lessons at the Auburn Lakes Pool through our outdoor lessons program know as Neighborhood Swim Lessons, LLC. NSL is part of Fun IN Swimming, Inc. and is a fully insured Limited Liability Corporation within the FINS family of businesses.

Thank you for the opportunity to partner with your community and to be a part of the continuing efforts to produce safer swimmers. Drowning is preventable!

Respectfully submitted,

Neighborhood Swim Lessons, LLC  
Bill Goudeket  
President

7827 Spring Cypress Road  
Spring, TX 77379

[www.funinswimming.com](http://www.funinswimming.com)

281-379-FINS  
[bill@funinswimming.com](mailto:bill@funinswimming.com)



a proposal for  
**Lee, Jerrod**

281-796-8809  
[jerrod@risherco.com](mailto:jerrod@risherco.com), [lifestyle@texaspubd.com](mailto:lifestyle@texaspubd.com)

25005 northcrest Dr  
spring  
Texas, 77375







Prepared on 3/7/2018 by  
**John Bates**



## About Us

Grand Slam A/V and Security is your expert partner for home automation, security and comfort. Through connected systems and creative solutions, we give you on-demand access to music and media, simplify your home and business systems, and help you protect what matters most. Best of all, we can provide you full access and control over your system from your smartphone.

## Pool Audio

Parts	unit cost	quantity	total
 <b>Episode</b> ES-AW-360-6-BRN Episode® Landscape Series 360° Speaker (Each)	\$459.95	6	<b>\$2,759.70</b>
 <b>Episode</b> ES-LS-SAT-6-BRN Episode® Landscape Series Satellite Speaker with 6" Woofer (Each) - Dark Brown	\$429.00	4	<b>\$1,716.00</b>
 <b>Crown</b> CDi4000 4000W POWER AMP W/DSP	\$1,908.90	1	<b>\$1,908.90</b>
 <b>Behringer</b> 802 8-Input 2-Bus Mixer, XENYX/EQ	\$89.99	1	<b>\$89.99</b>
 <b>Shure</b> BLX24-PG58 SHURE BLX24/PG58 SINGLE CH DTWIRELESS HANDHELD MIC SYSTEM	\$299.99	1	<b>\$299.99</b>
 <b>Direct Connect</b> DCRMW12U * DIRECTCONNECT 12U WALL MOUNT RACK UNIT ASSEMBLED FOR EQUIPMENT **** EXTRA FREIGHT ITEM ****	\$399.99	1	<b>\$399.99</b>

5

6

Proposal #333



About Us

2 of 6

Proposal #333

Pool Audio

3 of 6

Parts	unit cost	quantity	total
 <b>WattBox</b> WB-11-LIGHT Rack Mount Lighted Power Surge Protector - 11 Outlets	\$139.00	1	<b>\$139.00</b>
 <b>Binary</b> SP-164-DB-1000-BLK Cables 16 Gauge 4-Conductor 65- Strand CL2 Direct Burial Speaker Wire - 1000ft Drum (Black)	\$550.90	1	<b>\$550.90</b>

Labor	unit cost	quantity	total
Labor	\$1,975.00	1.00	<b>\$1,975.00</b>

### Project Total

Parts	\$7,864.47
<b>Discount</b>	<b>\$1,179.67</b>
Parts Total	\$6,684.80
Labor	\$1,975.00
Tax	\$714.43
<b>Grand Total</b>	<b>\$9,374.23</b>

### Payment Schedule

50% due upon approval, 50% due at completion.

All payment types accepted. A 3% processing fee will be added to credit card payments.

Pool Audio Total **\$9,839.47**

7

8

Proposal #333

Pool Audio

4 of 6

Proposal #333

Project Total

5 of 6

# Project Terms

Oakmont Utility District - 4195  
 W. Rayford @ Gosling  
 Spring, TX  
 Tina DeAsis;

Silverand Services

Estimate ID: 41754

Date: 3/12/2018

PROPOSAL  
 Division: Landscape  
 Type: Purchase

Sales Rep:  
 Mel Reist

Project Description:  
 Proposal to top dress the granite gravel at the west and east detention ponds to fit low and washed out areas only.

Alarm Monitoring will be:  
 \$47.77 a month for 3 years or  
 \$40.77 a month for 5 years

Qty	U/M	Description	Part Number	Price
<b>West detention pond</b>				
6		GRANITE GRAVEL (1.35 TDNS=1 CU YD.)		\$900.00
				<b>Total for West detention pond</b>
				<b>\$900.00</b>
<b>East detention pond</b>				
15		GRANITE GRAVEL (1.35 TDNS=1 CU YD.)		\$2,400.00
				<b>Total for East detention pond</b>
				<b>\$2,400.00</b>
<b>Labor to install</b>				
1		LABOR		\$500.00
				<b>Total for Labor to install</b>
				<b>\$500.00</b>
				<b>\$3,800.00</b>
				<b>Subtotal</b>
				<b>\$3,800.00</b>
				<b>Tax</b>
				<b>\$0.00</b>
				<b>Freight</b>
				<b>\$0.00</b>
				<b>Grand Total</b>
				<b>\$3,800.00</b>

**TERMS AND CONDITIONS:**

This Contract is entered into on this \_\_\_\_\_ day of \_\_\_\_\_, 20\_\_\_\_ by and between Silverand Services, Inc. "Contractor" and \_\_\_\_\_ "Client". Client agrees to pay Contractor the Contract Price of \_\_\_\_\_ in accordance with the Draw Schedule. Any alteration or deviation from the specifications in the Bid Proposal will be performed only upon execution of a written change order signed by Contractor and Customer, and must be paid in full prior to work being performed. (HT)

The Contract Price shall be adjusted to reflect any increase or decrease due to the change order.

Layout in the field will have precedence over the drawing, as adjustments are needed to accommodate drainage and existing trees. Bid has precedence over drawings. Not responsible for all preexisting underground elements.

**Limited Warranty:**

- Landscape Plants & Construction and also for Interior Plantings Company agrees to repair or replace plants and construction that fail within the first twelve months of installation. Failures are defined as unsatisfactory growth and structural failures except for defects resulting from abuse, lack of proper maintenance, neglect and incidents that are outside the company's control.
- Holiday Decorating and Containers for Interior & Exterior Landscape, Irrigation Products, Light Fixtures and Pool Equipment: Company provides the manufacturer's limited warranty against defects in material or workmanship.

**Payment Schedule**

\$3,800.00 Total Due on Completion

**Approval Signature:** \_\_\_\_\_

Pricing is good for 30 days from Date of Proposal  
 Silverand Services  
 2827 Barker Cypress - Houston, Texas 77084 - phone: 713-722-0336 fax: 713-722-8160

**Date:** \_\_\_\_\_

9

10

Oakmont Utility District - 4195  
 W. Rayford @ Gosling  
 Spring, TX  
 Tina DeAsis;

Silverand Services

Estimate ID: 41855

Date: 3/16/2018

PROPOSAL  
 Division: Landscape  
 Type: Purchase

Sales Rep:  
 Mel Reist

**Project Description:**

Proposal to add sod for bare and thin areas around the recreation center property. Areas will be identified on a map.

Qty	U/M	Description	Part Number	Price
<b>#1. Setback facing Northcrest Dr.</b>				
10		PALLET - BERMUDA SOD		\$3,500.00
1		LABOR TO GRADE		\$300.00
2		ENRICHED TOP SOIL (CU. YD.)		\$110.00
				<b>Total for: #1. Setback facing Northcrest Dr.</b>
				<b>\$4,510.00</b>
<b>#2. Areas inside pool fence</b>				
4		PALLET - BERMUDA SOD		\$1,400.00
1		LABOR TO GRADE		\$360.00
1.5		ENRICHED TOP SOIL (CU. YD.)		\$82.50
				<b>Total for: #2. Areas inside pool fence</b>
				<b>\$1,842.50</b>
<b>#3. Areas inside clubhouse path and pool fence/recreation</b>				
13		PALLET - BERMUDA SOD		\$4,550.00
1		LABOR TO GRADE		\$1,170.00
4		ENRICHED TOP SOIL (CU. YD.)		\$220.00
				<b>Total for: #3. Areas inside clubhouse path and pool fence/recreation curbs/bldgs.</b>
				<b>\$5,940.00</b>
<b>#4. Areas outside clubhouse path</b>				
25		PALLET - BERMUDA SOD		\$8,750.00
1		LABOR TO GRADE		\$2,250.00
6		ENRICHED TOP SOIL (CU. YD.)		\$330.00
3		STUMP GRINDING		\$375.00
				<b>Total for: #4. Areas outside clubhouse path</b>
				<b>\$11,705.00</b>
<b>#5. Area at new pool bldg with no irrigation</b>				
12		PALLET - BERMUDA SOD		\$4,200.00
1		LABOR TO GRADE		\$1,080.00
4		ENRICHED TOP SOIL (CU. YD.)		\$220.00
				<b>Total for: #5. Area at new pool bldg with no irrigation</b>
				<b>\$5,500.00</b>
				<b>\$29,497.50</b>
				<b>Subtotal</b>
				<b>\$29,497.50</b>
				<b>Tax</b>
				<b>\$0.00</b>
				<b>Freight</b>
				<b>\$0.00</b>
				<b>Grand Total</b>
				<b>\$29,497.50</b>

**TERMS AND CONDITIONS:**

This Contract is entered into on this \_\_\_\_\_ day of \_\_\_\_\_, 20\_\_\_\_ by and between Silverand Services, Inc. "Contractor" and \_\_\_\_\_ "Client". Client agrees to pay Contractor the Contract Price of \_\_\_\_\_ in accordance with the Draw Schedule. Any alteration or deviation from the specifications in the Bid Proposal will be performed only upon execution of a written change order signed by Contractor and Customer, and must be paid in full prior to work being performed. (HT)

The Contract Price shall be adjusted to reflect any increase or decrease due to the change order.

Layout in the field will have precedence over the drawing, as adjustments are needed to accommodate drainage and existing trees. Bid has precedence over drawings. Not responsible for all preexisting underground elements.

**Limited Warranty:**

- Landscape Plants & Construction and also for Interior Plantings Company agrees to repair or replace plants and construction that fail within the first twelve months of installation. Failures are defined as unsatisfactory growth and structural failures except for defects resulting from abuse, lack of proper maintenance, neglect and incidents that are outside the company's control.
- Holiday Decorating and Containers for Interior & Exterior Landscape, Irrigation Products, Light Fixtures and Pool Equipment: Company provides the manufacturer's limited warranty against defects in material or workmanship.

**Payment Schedule**

\$29,497.50 Total Due on Completion

**Approval Signature:** \_\_\_\_\_

Pricing is good for 30 days from Date of Proposal  
 Silverand Services  
 2827 Barker Cypress - Houston, Texas 77084 - phone: 713-722-0336 fax: 713-722-8160

**Date:** \_\_\_\_\_

11

12

## Tina Deases

---

**From:** Tina Deases <Lifestyle@Texaspub.com>  
**Sent:** Thursday, March 29, 2018 10:21 AM  
**To:** 'Mel Reist'  
**Subject:** Oakmont PUD approvals last night

Hi Mel, ,

Thanks so much for attending the Oakmont PUD board meeting last night. I am looking through the bids and wanted to visit with you regarding what was approved.

I show that the following were approved without changes: Estimate 41754 and 41963. 41754 we would like to have the work performed the first week of May.

I show that estimate 3920.01 was rolled into a modified estimate 41855. If I understand correctly you were going to work on zones 2, and 5 with the top left corner of 4 added in. Does that sound correct? Can you send me a new 41855 and circle the areas that will have sod added onto them?

I show that Estimate 42089 will be applied at a rate of \$255.00 and control inside the pool fence line and the area around the playground. Can you send me a revised estimate showing the new rate and areas?

Can you also send me a final copy of our landscaping contract? The board was under the impression that Smartline was already included and would like me to take a look at it.

Thanks again for doing such a great job out here!!

Thanks very much,

Tina DeAses  
Auburn Lakes Recreation Director  
281-255-2900  
Lifestyle@TexasPub.com

Oakmont Utility District - 4195  
W. Rayford @ Gosling  
Spring, TX

Silverand Services  
PROPOSAL  
Division: Irrigation  
Type: Purchase

Estimate ID: 39520.01  
Date: 10/30/2017  
Sales Rep:  
Felipe Santoyo

Project Description:  
Proposal to add sprays zone at area that don't have irrigation.

Qty	U/M	Description	Part Number	Price
1		IRRIGATION INSTALLATION WITH 1-1/2" VALVE IZ1.5"	IZ1.5"	\$1,200.00
Total for: Clock at Pool area / Recreation Center:				\$1,200.00
				\$1,200.00
Subtotal				\$1,200.00
Tax				\$0.00
Freight				
Grand Total				\$1,200.00

TERMS AND CONDITIONS:

This Contract is entered into on this \_\_\_\_\_ day of \_\_\_\_\_, 20\_\_\_\_ by and between Silverand Services, Inc. "Contractor" and \_\_\_\_\_ "Client". Client agrees to pay Contractor the Contract Price of \_\_\_\_\_ in accordance with the Draw Schedule. Any alteration or deviation from the specifications in the Bid Proposal will be performed only upon execution of a written change order signed by Contractor and Customer, and must be paid in full prior to work being performed. \_\_\_\_\_ (INT.)

The Contract Price shall be adjusted to reflect any increase or decrease due to the change order.

Layout in the field will have precedence over the drawing, as adjustments are needed to accommodate drainage and existing trees. Bid has precedence over drawings. Not responsible for all preexisting underground elements.

Limited Warranty:  
1. Landscape Plants & Construction and also for Interior Plantings: Company agrees to repair or replace plants and construction that fall within the first twelve months of installation. Failures are defined as unsatisfactory growth and structural failures except for defects resulting from abuse, lack of proper maintenance, neglect and incidents that are outside the company's control.  
2. Holiday Decorating and Containers for Interior & Exterior Landscape, Irrigation Products, Light Fixtures and Pool Equipment: Company provides the manufacturer's limited warranty against defects in material or workmanship.

Approval Signature: \_\_\_\_\_ Date: \_\_\_\_\_  
Pricing is good for 30 days from Date of Proposal  
Silverand Services  
2827 Barker Cypress - Houston, Texas 77064 - phone: 713-722-0336 fax: 713-722-8160

Initial: \_\_\_\_\_ Page 1  
(13)

Oakmont Utility District - 4195  
W. Rayford @ Gosling  
Spring, TX  
Tina DeAsis;

Silverand Services  
PROPOSAL  
Division: Landscape  
Type: Purchase

Estimate ID: 41963  
Date: 3/22/2018  
Sales Rep:  
Mel Reist

Project Description:  
Addition of asian jasmine to SB in bare areas and damage in the bed on circle island median front of clubhouse.

Qty	U/M	Description	Part Number	Price
24		JASMINE ASIAN 1 GAL		\$216.00
1		MULCH - BLACK (CU.YD.)		\$6.50
Total for:				\$222.50
				\$222.50
Subtotal				\$222.50
Tax				\$0.00
Freight				
Grand Total				\$222.50

TERMS AND CONDITIONS:

This Contract is entered into on this \_\_\_\_\_ day of \_\_\_\_\_, 20\_\_\_\_ by and between Silverand Services, Inc. "Contractor" and \_\_\_\_\_ "Client". Client agrees to pay Contractor the Contract Price of \_\_\_\_\_ in accordance with the Draw Schedule. Any alteration or deviation from the specifications in the Bid Proposal will be performed only upon execution of a written change order signed by Contractor and Customer, and must be paid in full prior to work being performed. \_\_\_\_\_ (INT.)

The Contract Price shall be adjusted to reflect any increase or decrease due to the change order.

Layout in the field will have precedence over the drawing, as adjustments are needed to accommodate drainage and existing trees. Bid has precedence over drawings. Not responsible for all preexisting underground elements.

Limited Warranty:  
1. Landscape Plants & Construction and also for Interior Plantings: Company agrees to repair or replace plants and construction that fall within the first twelve months of installation. Failures are defined as unsatisfactory growth and structural failures except for defects resulting from abuse, lack of proper maintenance, neglect and incidents that are outside the company's control.  
2. Holiday Decorating and Containers for Interior & Exterior Landscape, Irrigation Products, Light Fixtures and Pool Equipment: Company provides the manufacturer's limited warranty against defects in material or workmanship.

Payment Schedule  
\$222.50 Total Due on Completion

Approval Signature: \_\_\_\_\_ Date: \_\_\_\_\_  
Pricing is good for 30 days from Date of Proposal  
Silverand Services  
2827 Barker Cypress - Houston, Texas 77064 - phone: 713-722-0336 fax: 713-722-8160

Initial: \_\_\_\_\_ Page 1  
(15)

Oakmont Utility District - 4195  
W. Rayford @ Gosling  
Spring, TX  
Tina DeAsis;

PROPOSAL  
Division: Weathermatic  
Type: Installation

Estimate ID: 41906  
Date: 3/20/2018  
Sales Rep:  
Mel Reist

Project Description:  
Conversion of all controllers to Smartline controllers. Includes all equipment, weather station, installation and programming. Does not include battery operated Link controllers.

Qty	U/M	Description	Part Number	Price
1		48 ZONE STANDARD BUNDLE - MONTHLY FEE	FEE	\$70.00
1		48 ZONE STANDARD BUNDLE - INSTALLATION	INSTALL	\$0.00
Total for: Pool/Recreation Center				\$70.00
				\$70.00
Subtotal				\$70.00
Tax				\$0.00
Freight				
Grand Total				\$70.00

TERMS AND CONDITIONS:

This Contract is entered into on this \_\_\_\_\_ day of \_\_\_\_\_, 20\_\_\_\_ by and between Silverand Services, Inc. "Contractor" and \_\_\_\_\_ "Client". Client agrees to pay Contractor the Contract Price of \_\_\_\_\_ in accordance with the Draw Schedule. Any alteration or deviation from the specifications in the Bid Proposal will be performed only upon execution of a written change order signed by Contractor and Customer, and must be paid in full prior to work being performed. \_\_\_\_\_ (INT.)

The Contract Price shall be adjusted to reflect any increase or decrease due to the change order.

Layout in the field will have precedence over the drawing, as adjustments are needed to accommodate drainage and existing trees. Bid has precedence over drawings. Not responsible for all preexisting underground elements.

Agreement:  
Company agrees to repair or replace equipment that fails within the first 36 months of installation, with the exception of theft or abuse outside of the company's control.

Subtotal \$140.00  
Tax \$0.00  
Freight  
Monthly Total \$140.00

Approval Signature: \_\_\_\_\_ Date: \_\_\_\_\_  
Pricing is good for 30 days from Date of Proposal  
Silverand Services  
2827 Barker Cypress - Houston, Texas 77064 - phone: 713-722-0336 fax: 713-722-8160

Initial: \_\_\_\_\_ Page 1  
(14)

NC2812-2-part - NC3812-3-part

carbonless invoice

Evenflow Plumbing  
6314 Glenhill Ct  
Spring, TX 77389  
Kara Hughes  
281-787-3282  
RMP#42193

INVOICE NO. Invoice  
DATE: 4-23-2017  
CUSTOMER: OAKMONT UTILITY DISTRICT

SALE TO: Auburn Lakes Recreation Center

SALES PERSON: [Signature] QUOTE

DATE ORDERED	QTY ORDERED	DESCRIPTION	UNIT PRICE	TOTAL
		Replace bath fixtures, 120V water heaters with new water heater flex lines		1,875.00
		Remove heavy siding in location of the damaged pipe and make repairs		200.00
		Total:		2,075.00

(16)

A+ Spring Electric  
TECL19928  
P.O. Box 1302  
Spring, TX 77383

### Estimate

Date	Estimate #
3/8/2018	180308 2EST

Name / Address
Auburn Lakes Recreation Center Tina Deases 23083 Southeast Drive Spring, Texas 77389

Description	Qty	Cost	Project	
			Total	
1. Run new circuits for "barnet box" water heaters (5) (2-clubhouse, 2-fitness center, and 1-outdoor restroom). Estimated materials and labor to complete above		3,841.00	3,841.00	
<b>Total</b>			<b>3,841.00</b>	

Customer Signature \_\_\_\_\_

17

A+ Spring Electric  
TECL19928  
P.O. Box 1302  
Spring, TX 77383

### Estimate

Date	Estimate #
3/8/2018	180308 1EST

Name / Address
Auburn Lakes Recreation Center Tina Deases 23083 Southeast Drive Spring, Texas 77389

Description	Qty	Cost	Project	
			Total	
1. Run circuits and install (2) ceiling fans @ existing recessed lights in pool party area. All materials and labor to complete above		437.00	437.00	
<b>Total</b>			<b>437.00</b>	

Customer Signature \_\_\_\_\_

18



### Pool Light Repairs

**THIS AGREEMENT, Between Aquatic Management of Houston, Inc., (the "Company") and Auburn Lakes (Oaltonot PUD) (the "Customer"), shall constitute work to be performed by Company at Customer's pool. All work shall be completed in a professional manner and according to standard practices. Prices are for work as specified and under normal conditions. Prices do not include extra work required to correct problems caused by special conditions, such as hitting rock, water, debris, or by deterioration or poor condition of items not specified for repair below, or damage done as a result of demolition necessary to complete work.**

**Title: Pool Light replacement Total: \$ 5,583.00**

- Job description:
- 1) Remove current faulty pool lights (four 500W LED)
  - 2) Remove current faulty spa lights (two LED)
  - 3) Supply four (4) 120V 300W 150' LED pool light
  - 4) Supply two (2) 120V 100W 150' LED spa light
  - 5) Install new pool lights and run cable
  - 6) Electric connection to New Junction box
  - 7) Labor
  - 8) Clean up and haul off all trash and debris.

**LABOR INCLUDED IN PRICE  
PRICE DOES NOT INCLUDE TAX**

**Warranty.** If any product or service provided by Company does not function properly, Company will, at our option, repair or replace any equipment we supplied at no charge for a period of 12 months from the date of installation, or repair any damage caused by faulty workmanship within 12 months from the date of providing of service. This is the sole warranty given for products and workmanship.

This warranty is limited to the terms stated herein. All expressed and implied warranties are excluded, except as stated above.

Customer agrees to furnish, at no cost to Company, water and electricity for Company's use in performing the work described herein.

Company accepts no responsibility for hydrostatic lifting. Any risks involved in draining the pool shall be solely the Customer's.

**Payment shall be made as follows:**  
Payments will be invoiced. The balance will be due upon completion. Any payments not made on or within ten (10) days after the due date thereof shall be subject to a delinquent payment fee of 1 1/2% per month or portions of any months.

In the event that the Company is obligated to file suit or lien to recover payment of any sums under this Agreement, Customer agrees to bear all reasonable costs of attorney fees.

ACCEPTED:

Peter Clark, President

Auburn Lakes

19

20

DATE: _____	DATE: _____
-------------	-------------



**Aquatic Management**

- Pool quotes from Peter via email...
- 2 led lights 4-500 watt LED, 2 spa LED - attached
- 6 gauges for main pipe shut off and other - pressure gauges - needed to know more about rate of return and efficiency of system are \$15.06 each
- 7 jay box work on pool deck, John noticed problems that need to be repaired at the jay box on the pool deck- included with pool light work proposal
- 9 replace 1 skimmer basket - \$42.35
- 10 replace 3 rescue tubes - \$66.85 each
- 13 no diving signs - \$27.23 each
- 14 Pool return outlet covers - \$7.86 each



March 20<sup>th</sup>, 2018

**Proposal & Contract**

We are pleased to submit the following specifications and estimates for...

Attn: Peter Clark

Auburn Lakes Rec Center  
25005 Northcrest Dr.  
Spring, TX 77389  
281-466-5003  
[peter.clark@houston-pmr.com](mailto:peter.clark@houston-pmr.com)

**Work Scope**

Deck Options:

- Cut holes in deck for flag poles with Deck Texture Touch Up\* (6 pole sleeves) \_\_\_\_\_ \$ 1,750.00  
\*poles not included
- Grind & Clean Sides of All Existing Deck Joints with Paint Touch Up 2,550 lf \_\_\_\_\_ \$ 1,950.00
- Pressure Wash & Clean All Existing Spray Deck 10,300 sq ft \_\_\_\_\_ \$ 3,250.00

Contractor and Owner Defined

Houston Pool Renovations, LLC of Houston, Texas is hereafter, "Contractor."  
Auburn Lakes Rec Center of Houston, Texas is hereafter, "Owner."

Contract Acceptance - Owner:

Houston Pool Renovations, LLC agrees that all work will be completed in a workmanlike manner according to standard industry practices, but shall not be responsible for delay or failure to perform work when such delay or failure is due to reasons beyond its control (i.e. weather). Houston Pool Renovations is not responsible for any damages to existing sprinkler lines, cable/telephone lines, utility lines, or any sod/plants damaged during construction process. Any alterations or deviation from above specifications involving extra costs will be performed only upon a new revised proposal by the contractor. Our workers are fully covered by Workmen's Compensation Insurance.

Water and Electricity are necessary for our work and must be available on-site. Customer must keep area free from other workmen, pets, and children. Water (sprinklers) must be turned OFF during application. Houston Pool Renovations also needs close access to pool when performing the work, this often requires use of homeowner's driveway. Therefore, Houston Pool Renovations is not responsible for cracks to driveway or any other concrete due to need of access to perform the work. Please remove any vehicles prior to crew arriving.

Payment Schedule: (Final contract price will be determined based on selections above)  
100% Upon Completion

The above costs are figured with a Cash or Check Discount. If paying by Credit Card increase the individual or total contract price by 3%.

Contract Work Scope Changes:

Any changes to the terms and conditions of this Contract or Contractor's work scope shall be identified and the Owner notified before Contractor performs such changes. Owner and Contractor shall agree as to the necessity and costs of any and all Contract changes in writing before such changes are made.

Owner and Contractor agree to be bound by the terms and conditions set forth in this proposal and contract. The above prices, specifications and conditions are satisfactory and are hereby accepted. You have authorized Houston Pool Renovations, LLC to do the work as specified.

Owner \_\_\_\_\_ Date \_\_\_\_\_

Contractor \_\_\_\_\_ Date \_\_\_\_\_

9505 W Tidwell  
Houston, TX 77041

[www.houstonpoolrenovations.com](http://www.houstonpoolrenovations.com)

office: 713-466-3300  
fax: 713-466-3566

22

22

Proposal & Contract submitted by:  
Jared Munos - Sales Manager  
Houston Pool Renovations, LLC.  
832-554-2300 office  
713-816-1544 cell  
[jared@houstonpoolrenovations.com](mailto:jared@houstonpoolrenovations.com)

**Malibu Aquatics**  
9550 Spring Green Blvd. STE. 408-361  
katy, TX 77494  
(832) 819-6046  
scott@malibuqa.com  
malibuqa.com



**ESTIMATE**

ADDRESS  
Tina Deases  
Auburn Lakes  
25005 Northcrest Dr  
Spring, TX 77389

ESTIMATE # 1002  
DATE 02/12/2018

SERVICE	QTY	RATE	AMOUNT
Power washing entire pool deck. This includes the side areas by the pump room. Also the main entrance areas of the facility.			
Hour Labor	8	95.00	760.00
Please sign and send back			
		SUBTOTAL	760.00
		TAX (8.25%)	62.70
		TOTAL	<b>\$822.70</b>

Accepted By

Accepted Date

23

24



GREATER HOUSTON POOL CONSTRUCTION & REPAIR SERVICES

To: Auburn Lakes
C/O: Tina Deases
Date: 1/15/2018

We are pleased to submit the following bid to install 4 new Pole Anchors for the Auburn Lakes Community pool.

Installation of 4x new pole anchors

- Locate and mark location of new anchors
Property manager to review location, document, and approve prior to drilling
Core drill deck and clean of debris
Bond and set new anchors

Cost: \$1220.00

OPTIONAL ITEMS:

Installation of 5x new Starting Block anchors

- Locate and mark location of new anchors
Property manager to review location, document, and approve prior to drilling
Core drill deck and clean of debris
Bond and set new anchors

Cost: \$1,525.00

Installation of 2x new Recall Rope anchors

- Locate and mark location of new anchors
Property manager to review location, document, and approve prior to drilling
Core drill deck and clean of debris
Bond and set new anchors

Cost: \$600.0

This proposal does not include unforeseen issues; we will alert you if additional parts and/or labor may apply for your approval.

Greater Houston Pool Management, Inc. hereby agrees to furnish labor and materials in accordance with the above specifications. All material is guaranteed to be as specified. All work is to be completed in a workable manner according to standard practices. Any labor or deviation from the above specifications involving extra costs, will be performed only on written orders, and will be charged over and above the original bid submission. This proposal is subject to acceptance in thirty (30) days, and is void thereafter at the option of Greater Houston Pool Management, Inc.

ACCEPTED: Russell Mitchell via email
GHPM Representative # 50912 DATE: 1/15/2018
Representative DATE:

GREATER HOUSTON POOL MANAGEMENT
12227 Old Huffmeister Road > Cypress, Texas > (Tel) 713.771.7665 > (Fax) 713.771.7946
www.greaterhoustonpool.com

25

Malibu Aquatics
9550 Spring Green Blvd. STE. 408-361
katy, TX 77494
(832) 819-6046
scott@malibuqa.com
malibuqa.com



ESTIMATE

ADDRESS
Tina Deases
Auburn Lakes
25005 Northcrest Dr
Spring, TX 77389

ESTIMATE # 1007
DATE 03/06/2018

Table with columns: SERVICE, QTY, RATE, AMOUNT. Includes problem description, solution, and pricing details for expansion joint removal and replacement.

By signing this you are authorizing Malibu Aquatics to perform the list of services above. Unforeseen repairs not included in this bid will be addressed. A separate bid will be sent out.

SUBTOTAL 14,375.00
TAX (8.25%) 1,185.94
TOTAL \$15,560.94

Accepted By Accepted Date

21

Quote 1 remove material from all 2500 linear feet of expansion joints and replace with new self-leveling caulk \$17,500.00

Quote 2 grinding, sanding, re-sealing all 2500 linear feet of expansion joints and replace with slab gasket \$35,000.00

Quote 3 removing material from approximately 450 linear feet of expansion joints & re-sealing and replacing with new caulk \$3,600.00

Quote 4 grinding, sanding, re-sealing approximately 450 linear feet of expansion joints and replacing with slab gasket \$6,800.00

Jared M - Sales Manager
Pool Works, LLC/Deck Works, LLC
9505 W. Tidwell
Houston, TX 77041
O: 713-466-3300
F: 713-466-3566
E: jared@poolworksrv.com
W: www.houstonpoolrenovations.com

Malibu Aquatics
9550 Spring Green Blvd. STE. 408-361
katy, TX 77494
(832) 819-6046
scott@malibuqa.com
malibuqa.com



ESTIMATE

ADDRESS
Tina Deases
Auburn Lakes
25005 Northcrest Dr
Spring, TX 77389

ESTIMATE # 1006
DATE 03/06/2018

Table with columns: SERVICE, QTY, RATE, AMOUNT. Includes problem description, solution, and pricing details for expansion joint removal and replacement.

By signing this you are authorize Malibu Aquatics to perform the list of services above. Unforeseen repairs not included in this bid will be addressed. A separate bid will be sent at that time

SUBTOTAL 18,125.00
TAX (8.25%) 1,495.31
TOTAL \$19,620.31

Accepted By Accepted Date

26

28

**Malibu Aquatics**  
 9550 Spring Green Blvd. STE 408-361  
 Katy, TX 77494  
 (832) 819-8046  
 scott@malibuqa.com  
 malibuqa.com



**Malibu Aquatics**  
 9550 Spring Green Blvd. STE.408-361  
 Katy, TX 77494  
 (832) 819-8046  
 scott@malibuqa.com  
 malibuqa.com



**ESTIMATE**

**ADDRESS**  
 Tina Deases  
 Auburn Lakes  
 25005 Northcrest Dr  
 Spring, TX 77389

**ESTIMATE # 1004**  
**DATE 02/28/2018**

SERVICE	QTY	RATE	AMOUNT
Problem: approximately 437 linear feet of expansion joints located on the pool deck need to be cut out and replaced. Solution: Cut out approximately 437 linear feet of Worm, cracked and discolored mastic from the pool deck. This will be done by saw cutting and cleaning out the expansion joints. Once expansion joints are clear, back fill them with sand and or backer rod. Then install a color matching self leveling mastic to fill-in expansion joints and let cure for 48 hours.	437	5.75	2,512.75T
<b>Bates</b> Price per linear foot			
Malibu Aquatics Will offer a one year replacement warranty on material and labor.			

By signing this you are authorizing Malibu Aquatics to perform the list of services above. Unforeseen repairs not included in this bid will be addressed. A separate bid will be sent out.

**SUBTOTAL** 2,512.75  
**TAX (8.25%)** 207.30  
**TOTAL** **\$2,720.05**

Accepted By \_\_\_\_\_ Accepted Date \_\_\_\_\_

29

**ESTIMATE**

**ADDRESS**  
 Tina Deases  
 Auburn Lakes  
 25005 Northcrest Dr  
 Spring, TX 77389

**ESTIMATE # 1005**  
**DATE 02/28/2018**

SERVICE	QTY	RATE	AMOUNT
Problem: Approximately 437 linear feet of expansion joints located on the pool deck need to be cut out and replaced. Solution: Cut out approximately 437 linear feet of Worm, cracked and discolored mastic from the pool deck. This will be done by saw cutting and cleaning out the expansion joints. Once expansion joints are clear, install new slab gasket by using a soft mallet to set into place.	437	7.25	3,168.25T
<b>Bates</b> Price per linear foot.			
Note: Mastic may have to be used in junction points were slab gasket will not meet up correctly. Malibu Aquatics Will offer a one year replacement warranty on material and labor.			

By signing this you are authorizing Malibu Aquatics to perform the list of services above. Unforeseen repairs not included in this bid will be addressed. A separate bid will be sent out.

**SUBTOTAL** 3,168.25  
**TAX (8.25%)** 261.38  
**TOTAL** **\$3,429.63**

Accepted By \_\_\_\_\_ Accepted Date \_\_\_\_\_

30

Quote #27160 - 3/7/2018

1 of 2



Manufacturer's Sales Representative  
 Tommy Davis  
 Phone: 817-601-5898  
 email: tommy@tropicenterprises.com

Quote #27160

Product #	Description	Special Instructions	Unit Price	Quantity	Total
84150ALR	(84150ALR) Aria Woven Left/Right Side Module Finish: Kalea (KAF) Fabric: Cate (Z7513)	Side Mark 1: Auburn Lakes Side Mark 2: 2.1M, 2 Right modules	\$791.84	1	\$3,168.25
84140MC	(84140MC) Aria Woven Armless Module Finish: Kalea (KAF) Fabric: BACKSEAT Cate (Z7513)	Side Mark 1: Auburn Lakes	\$730.00	2	\$1,460.00
220424	(220424) Millrose Rattan Dining Chair Finish: Greco (GRE) Fabric: Cate (Z7513)	Side Mark 1: Auburn Lakes	\$125.00	12	\$1,500.00
84795BZ	(84795BZ) Bridgewood 48" Round Dining Umbrella Table Finish: Greco (GRE)	Side Mark 1: Auburn Lakes	\$330.00	3	\$990.00
BCH0008B	(BCH0008B) Portofino 8' Hexagon 6' Manual Lift Umbrella Finish: Greco (GRE) Fabric: Cate (Z7513)	Side Mark 1: Auburn Lakes	\$382.00	3	\$1,146.00
CFAZDR15T	(CFAZDR15T) Constant Filled Aluminum Base 20" Round 1.5" Polk. Table Height Finish: Greco (GRE)	Side Mark 1: Auburn Lakes	\$66.00	3	\$258.00

Subtotal \$6,460.56  
 Tax \$760.48\*  
 Shipping \$757.15  
 Order total \$7,978.19

\* Freight tax included.

\*\*\* This quote may reflect an approximate tax and freight amount. You will be responsible for Actual Charges calculated at time of ship, which will be reflected on your invoice. \*\*\*

Project Name/Purchase Order Number:  
 Auburn Lakes - 1st order

**Billing Information:**  
 Tina Deases  
 Auburn Lakes HOA  
 25005 Northcrest Dr  
 Spring, TX 77389  
 United States  
 Phone: 281-255-2800  
 Email: tdeases@tropicenter.com

**Shipping Information:**  
 Tina Deases  
 Auburn Lakes HOA  
 25005 Northcrest Dr  
 Spring, TX 77389  
 United States  
 Phone: 281-255-2800  
 Email: tdeases@tropicenter.com

**Comments**  
 There are no comments for this quote.

31

Quote #27160 - 3/7/2018

2 of 2

Note  
 Installation Charge: includes handling, unboxing, assembly, delivery and installation. Our team of trained installers will site educate your staff on the care and maintenance of the new furniture. \$1218.00  
 Lead time: 4 Weeks  
 Payment Terms: PAYMENT IN ADVANCE

Approval

Authorized Signature \_\_\_\_\_  
 Date \_\_\_\_\_

32



Manufacturer's Sales Representative  
Tommy Davis  
Phone: 817-501-6598  
email: tommy@tropicatse.com

Quote #27162

Product #	Description	Special Instructions	Unit Price	Quantity	Total
641510MR	(641510MR) Acc. Woven Ladderback Side Module Fabric: Calk (27515) Finish: Kaffee (KAF)	Side Mark 1: Auburn Lakes Side Mark 2: 2 left, 2 right module	\$791.04	4	\$3,164.56
641410MC	(641410MC) Acc. Woven Armless Module Fabric: (BACK/SEAT) Calk (27515) Finish: Kaffee (KAF)	Side Mark 1: Auburn Lakes	\$730.00	2	\$1,460.00
220424	(220424) Millennia Relaxed Ring Dining Chair Finish: Greco (GRE) Fabric: Calk (27515)	Side Mark 1: Auburn Lakes	\$129.00	20	\$2,580.00
647NSBU	(647NSBU) Boulevard 48" Round Dining Umbrella Table Finish: Greco (GRE)	Side Mark 1: Auburn Lakes	\$330.00	5	\$1,650.00
60H008MS	(60H008MS) Portofino II, Hexagon 6' Manual LR Umbrella Finish: Greco (GRE) Fabric: Calk (27515)	Side Mark 1: Auburn Lakes	\$362.00	3	\$1,086.00
CFA20R15T	(CFA20R15T) Cement Filled Aluminum Base, 20" Round, 1.5" Pole Table Height: Finish: Greco (GRE)	Side Mark 1: Auburn Lakes	\$86.00	3	\$258.00
Subtotal					\$11,010.56
Tax					\$885.25*
Shipping					\$962.21
Order Total					\$12,858.02

\* Freight tax included.

\*\*\* The quote may reflect an approximated tax and freight amount. You will be responsible for Actual Charges calculated at time of ship, which will be reflected on your invoice. \*\*\*

Project Name/Purchase Order Number:  
Auburn Lakes - 1/2 order

Billing Information:  
Tina DeJes  
Auburn Lakes HOA  
25003 Northcross Dr  
Spring, TX 77386  
United States  
Phone:  
281 264 2900  
Email:  
aclub@alakes.com

Shipping Information:  
Tina DeJes  
Auburn Lakes HOA  
25003 Northcross Dr  
Spring, TX 77386  
United States  
Tina DeJes - 281-235-2900

Comments

There are no comments for this quote.

33

34



Eliot Burke  
General Manager  
Precision Design Signs  
O- 281 364 8440  
C- 281 906 2539

15 Realtor Signs - Single Sided (realtor signs that have an H frame with plastic signage?) \$19.50 each  
Total of 15 yard signs - full color print - 4 mm corrugated plastic \$292.50  
Emergency phone sign (2 color print, 18 x 24, same material as our original sign) \$120 \$120.00  
Stickers for existing pool signs and add new pool contact information. \$30.00 \$30.00  
2 Laminated Posters - \$45 each \$90.00

Total: \$532.50

37

Note

Installation Charge: Includes reworking, unbolting, assembly, delivery and installation. Our team of trained installers will also educate your staff on the care and maintenance of the new furniture. \$1128.00

Lead time: 4 weeks

Payment Terms: PAYMENT IN ADVANCE

Approval

Authorized Signature

Date

1) 15 Double sided coroplast signs with metal wire H stakes \$14.50 each \$217.50  
2) Metal or Alupanel 18 x 24 laminated single sided - \$55 each \$110  
3) 2 Stickers - \$9 each \$18  
4) 2 Laminated posters - \$36 each \$72  
Total: \$417.50

We do offer price match policy if we are already not cheaper than our competitors so please let us know and we will beat any price by minimum of 5% or more.

Best Regards,  
Nitin  
Value Print & Ship  
"Your One Stop Shop for Printing & Shipping Needs"  
281-528-0422

36

**Risher Fitness Equipment Inc.**  
 7902 Westwood Drive  
 Houston, TX 77055  
 (713) 419-8667  
 Equipment@risherco.com  
 http://www.RisherCo.com

**Quote**



ADDRESS  
 Auburn Lakes Recreation Center  
 Northcrest Dr  
 Spring, Texas 77389

QUOTE # 4816      DATE 03/07/2018      EXPIRATION DATE 06/29/2018

DESCRIPTION	QTY	RATE	AMOUNT
Troy 85 Lb. 12-Sided Rubber Encased Dumbbell	1	160.65	160.65T
Troy 90 Lb. 12-Sided Rubber Encased Dumbbell	1	170.10	170.10T
TKO Vertical Dumbbell Rack	1	384.00	384.00T
Concept 2 Model D Indoor Rower with PM5	1	900.00	900.00T
Shipping and Install	1	215.76	215.76T
<b>SUBTOTAL</b>			1,830.53
<b>TAX (0%)</b>			0.00
<b>TOTAL</b>			<b>\$1,830.53</b>

Josh Mann  
 Regional Mgr./Risher Fitness Equipment  
 cell: 713 419 8667 fax: 832 201 6796  
 Josh@risherco.com  
 www.RisherCo.com

SUBTOTAL  
 TAX (0%)  
 TOTAL

Accepted By

Accepted Date



37

38

\*Clients with a confirmed install date who request rescheduling with less than a 72 hour notice are subject to a \$300 rescheduling fee.  
 \*All electrical and cable requirements are to be in place upon installation to avoid a return trip charge.  
 \*For all Credit Card payments there will be a 4.5% office administration fee.

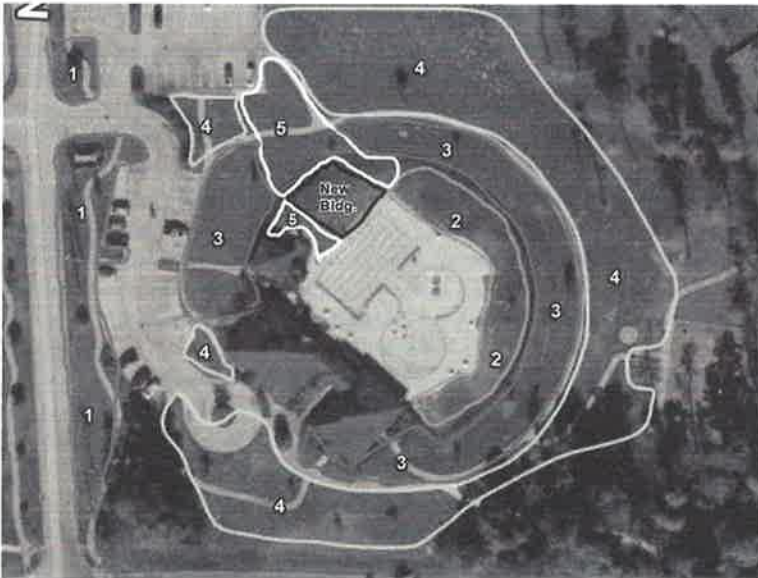

39

**SmartLink™**  
Wireless Landscape Network

**Introducing SmartLink.**  
The world's first intelligent, affordable, web-based irrigation control system.

**IT'S TIME TO SAVE WATER AND BEAUTIFY YOUR LANDSCAPE WITH THE SMARTLINK™ NETWORK**

Imagine having immediate access to every element of your irrigation system. With the SmartLink Wireless Landscape Network you and your landscape professional have unprecedented control over your system.

**What does this mean to you?**

Now your landscape professional is capable of making a simple programming change, monitoring the health of the system, or even being alerted if a problem occurs. He can instantly shut down your system in an emergency and help you comply immediately with local watering restrictions, avoiding costly fines.

COMPUTER

SMARTPHONE

TABLET

Full access to the SmartLink Network on any device that connects to the internet. Adjusting all smart controls is a quick and easy process. And when trouble happens, you get visibility, knowing exactly how much water you are saving.

**smartlinknetwork.com**

40



## SmartLink

Weather Conserving Network

### A Smarter way to save.

Conventional timer-based systems water on weekly schedules that once programmed, are rarely changed. Because of this, they tend to overwater by 20-60%. They also do not take into account seasonal, soil, plant and weather conditions. Overwatering injures plants and creates runoff that can lead to costly damage to pavement and walkways. Not to mention, it's embarrassing.

The SmartLink Controller is the water-saving control system in SmartLink. It has been installed on more than 200,000 properties saving an average of 28% in water use by taking into account all the necessary conditions to maximize irrigation efficiency.



**16000 WATER BILL**

100%  
75%  
50%  
25%  
0%

**16% EXCESS WATERING**

**02% LANDSCAPE REQUIREMENT**

### What SmartLink can do for you.

[smartlinknetwork.com](http://smartlinknetwork.com)

**Dramatic Water Savings.**  
Saves an average of 28% on water with auto adjust features which precisely irrigate.

**Landscape Beautification.**  
Weather-sensitive irrigation avoids over-watering or under-watering to extend plant life.

**Real-Time Reporting.**  
Water saving reports help you regularly see the benefits of Smart weather-based irrigation.

**Freeze Prevention.**  
Automatically prevents watering during freezes.



**Reduce Hardscape Damage.**  
Avoid costly damage to pavements and parking lots from water runoff.

**Immediate Compliance.**  
Web-based programming lets you comply with water restrictions to avoid costly fines.

**Web-Based Control.**  
Enable your contractor to instantly shut-down your system in an emergency.

**Equipment Assurance.**  
Equipment warranty for cover lightning, theft, and physical damage.

**Leak Savings.**  
When the SmartLink Flow Sensor is installed, it will provide critical information used to take water management to a new level.





## NOW YOU HAVE CONTROL OF YOUR CONTROLLER

The most important part of an irrigation system is the controller. Like the dashboard of a car, you need to have critical information provided to you in order to drive. Sadly, conventional controllers do not have the technology to give you the feedback and control needed to run your system efficiently. There's nothing conventional about SmartLink. Go Smart. Go SmartLink.

Conventional Sprinkler Timer	SmartLink
Loses time programming and landscape	Remote time adjust program. No factory is required for adjustments to be done.
Non-compliant with watering day restrictions - frequent fines that in some cases, non-compliance and illegal to install in many areas.	Complies with watering day restrictions and seasonal water programming with seasonal control (seasonally required in some California counties).
Low efficiency = over watering to limit landscape loss due to weather changes.	High efficiency = seasonal water based watering times based on the weather to save plants.
No remote access for urgent programming changes.	Remote access for emergency events, allow shut-down and restart at any time to limit liability.
No remote monitoring or reporting.	Real-time monitoring and reporting of water usage.
1 year and commonly required equipment warranty usually covers manufacturer defects.	Lifetime of service equipment warranty includes coverage for lightning, theft, and physical damage.

THE SMARTLINK NETWORK INCLUDES THE SMARTLINK CONTROLLER, SMARTLINK AIRCARD AND WEATHER STATION, COMBINED. THERE'S NOTHING ELSE LIKE IT.

## SmartLink

Weather Conserving Network

### ESTIMATE YOUR SMARTLINK SAVINGS

An Investment that Quickly Pays You Back

The average property owner with a 1/2-acre, 1-acre site will spend well over \$1,000 on irrigation water per year. The SmartLink Network has been installed in thousands of sites and, averages water savings of 28%, providing an payback in twelve months or less.

Annual Water Bill	10%	20%	30%	40%	50%
\$1,000	\$900	\$800	\$700	\$600	\$500
\$2,500	\$2,250	\$2,000	\$1,750	\$1,500	\$1,250
\$5,000	\$4,500	\$4,000	\$3,500	\$3,000	\$2,500
\$10,000	\$9,000	\$8,000	\$7,000	\$6,000	\$5,000
\$20,000	\$18,000	\$16,000	\$14,000	\$12,000	\$10,000
\$50,000	\$45,000	\$40,000	\$35,000	\$30,000	\$25,000
\$100,000	\$90,000	\$80,000	\$70,000	\$60,000	\$50,000

Not all savings will be exactly the same based on weather, water rates, historical watering practices and overall controller system efficiency.

[smartlinknetwork.com](http://smartlinknetwork.com)



**Weathermatic**  
Water Conserving Innovation

**Weathermatic Headquarters**  
1101 W. 10th Street  
Tulsa, OK 74106  
918-484-2722  
www.weathermatic.com

## Silversand Services

now offers a powerful, cloud-based, irrigation water management system for your property.

- Significantly less water is applied to the landscape - up to a 50% savings - all while maintaining plant health and beauty
- Complete irrigation system visibility and performance reporting assist in managing water use
- Regular interaction with your irrigation controller can be performed remotely, via the cloud, so the vital programming adjustments can happen in an instant
- Ensures you're compliant with the frequent irrigation watering restrictions, avoiding costly fines and unwanted public attention
- Captures all irrigation system maintenance inspections, providing a comprehensive overview of the issues discovered. Photographs of these issues can be attached to help add clarity and resolution
- Notifications and Alerts caused by unforeseen events to the irrigation system drastically increases the response time to correct

**COMPLETE PEACE OF MIND THAT OUR MOST VALUABLE RESOURCE IS BEING CARED FOR. WATER.**

**SmartLink**  
by Weathermatic

[silversandservices.com](http://silversandservices.com)

46

Page 1

Approved Signature: \_\_\_\_\_  
Date: \_\_\_\_\_

1. Laminated Plates & Containers and also for laminated Plates & Containers except for dishes, plates and containers that are the  
laminated plates and containers and also for laminated Plates & Containers except for dishes, plates and containers that are the  
laminated plates and containers and also for laminated Plates & Containers except for dishes, plates and containers that are the

Order: 10/17/2018  
Date: 10/17/2018  
Page 1 of 1

45

Page 1

Approved Total: \$770.00

Subtotal: \$770.00

Tax: \$0.00

Total: \$770.00

1. AZOON ANTIBIOTIC TREATMENT

Product Description: \_\_\_\_\_

Type: Purchase

Division: Specialty Service-C

Date: 3/28/2018

Order: 10/17/2018

Page 1 of 1



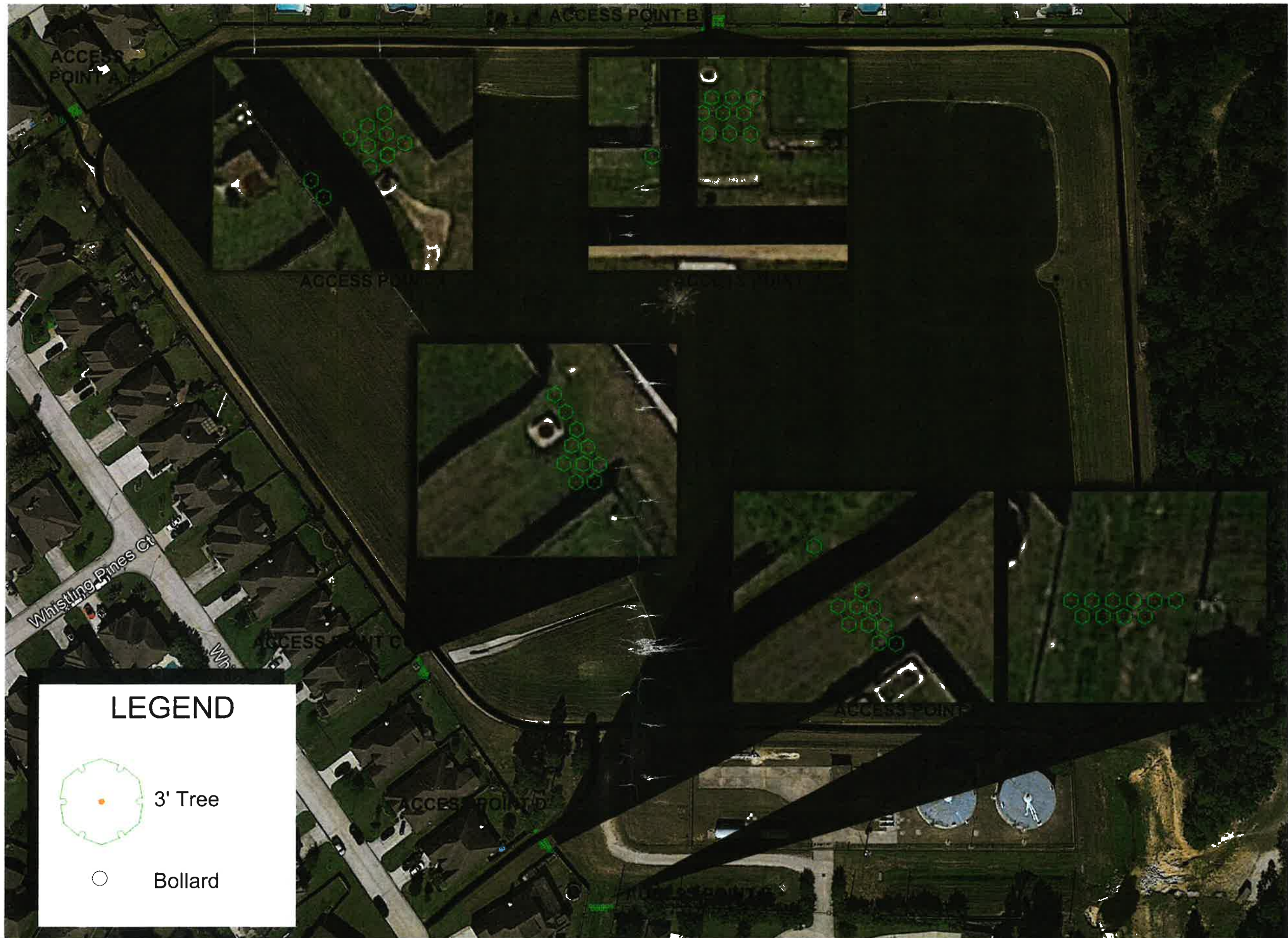

**LEGEND**

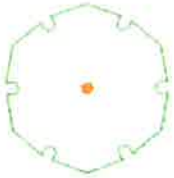
 3' Tree

 Bollard

**EXHIBIT**  
 C

March 2018

Oakmont PUD  
 Tree and Stake/Bollard Plan



This drawing depicts conceptual landscape improvements for illustrative purposes. Final design solutions are subject to change.



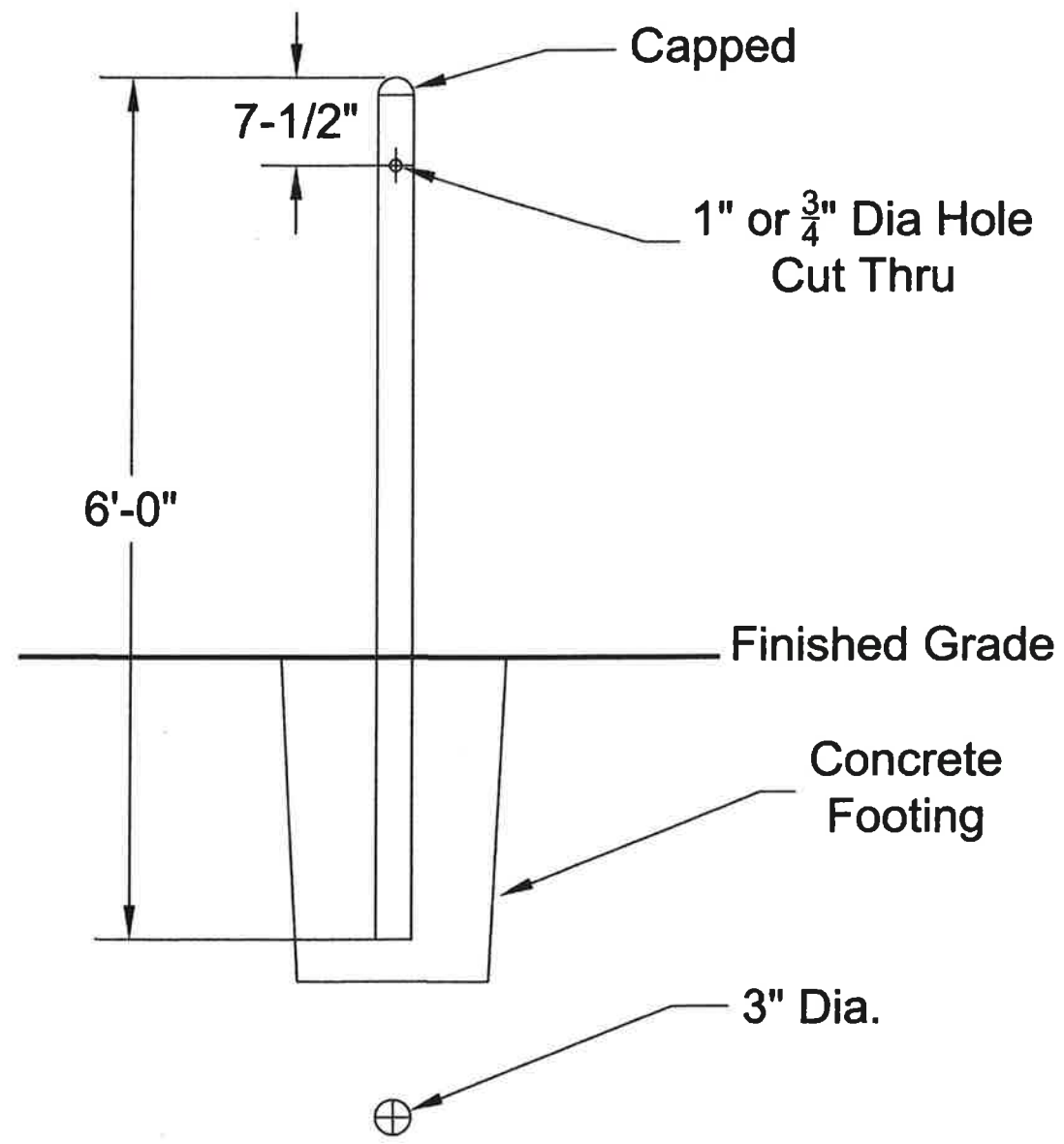

Tree Stake - Painted with Camo/Bark Pattern



Camo/Bark Pattern #1



Camo/Bark Pattern #2



Camo/Bark Pattern #3



Camo/Bark Pattern #4



Camo/Bark Pattern #5



Camo/Bark Pattern #6

3 Part Paint Process

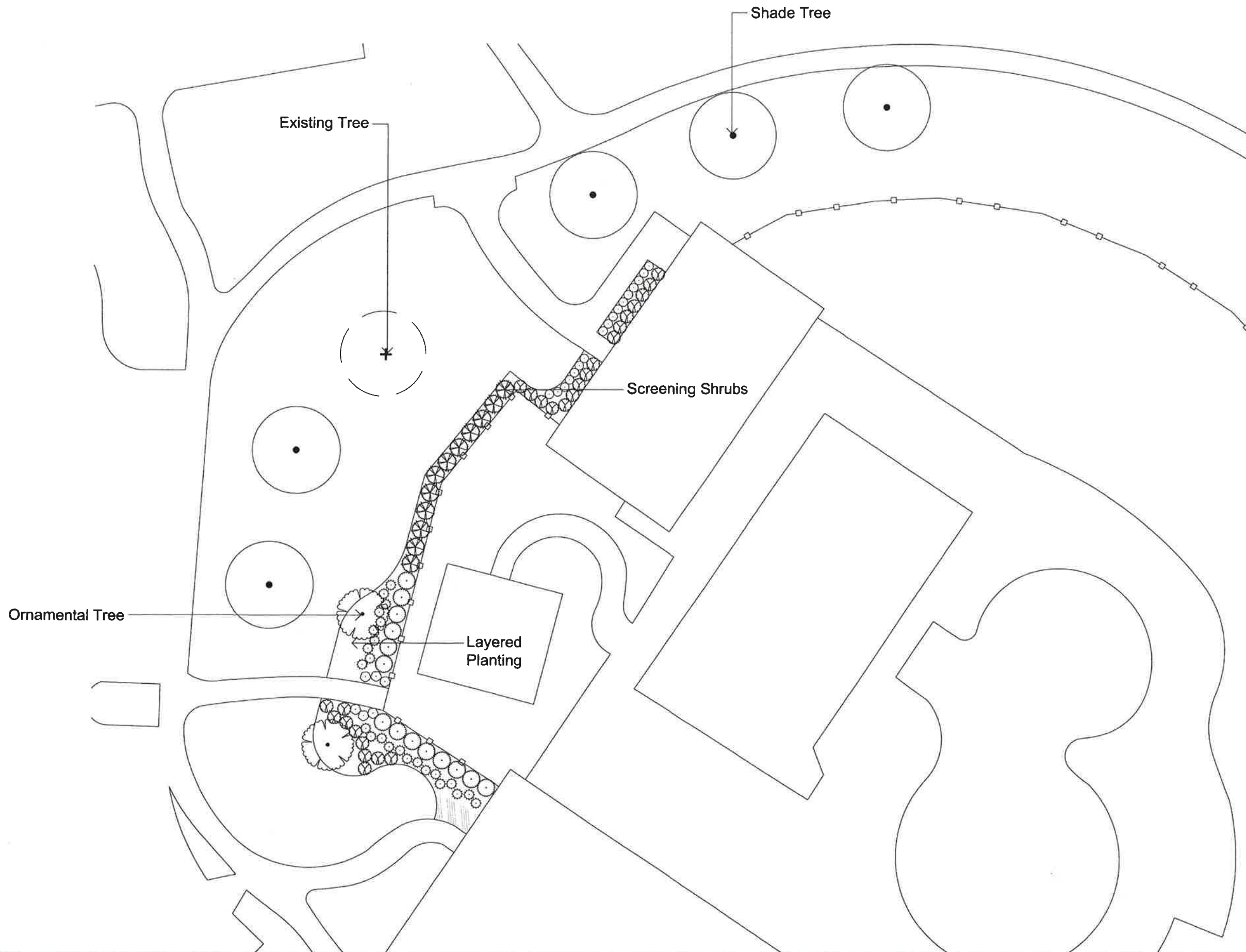

March 2018

Oakmont PUD  
 Preliminary Design for Landscape Beds Outside Fence Area



This drawing depicts conceptual landscape improvements for illustrative purposes. Final design solutions are subject to change.



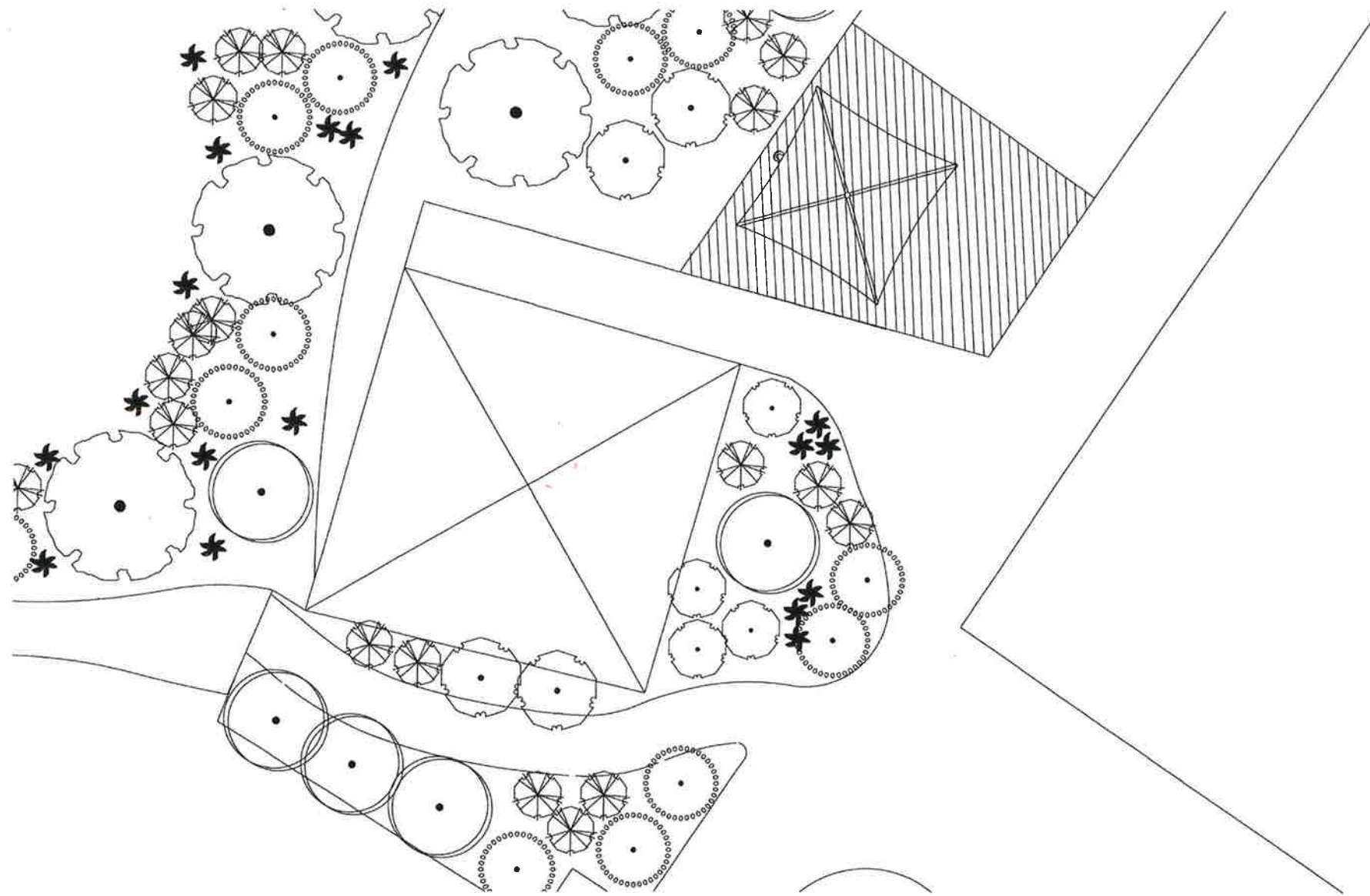

 Pour in Place 325 sq ft @ \$20 sq.ft = \$6,500

 Shade Structure/Umbrella (12'x12') = \$10,000

March 2018

Oakmont PUD  
Estimates for Shade & Pour in Place



This drawing depicts conceptual landscape improvements for illustrative purposes. Final design solutions are subject to change.



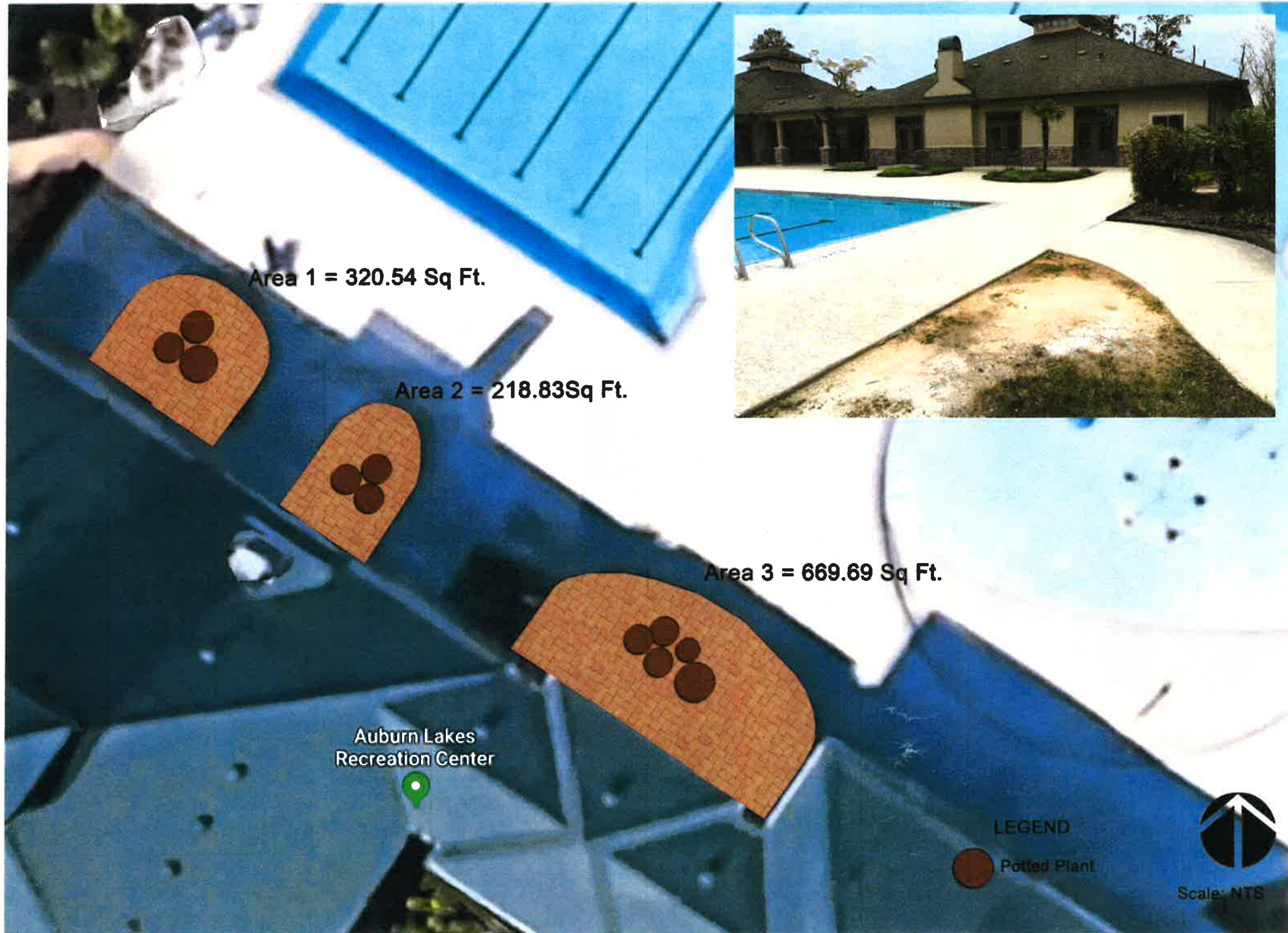

**Potted Plant Container #1**  
 23" - \$600  
 40" - \$600  
 48" - \$600

**Potted Plant Container**  
 \$150 for EACH

**Hardscape** ☑ x \$15  
 Area 1. 321 sq.ft x \$15 = \$4,815  
 Area 2. 219 sq.ft x \$15 = \$3,285  
 Area 3. 670 sq.ft x \$15 = \$10,050

**3 Areas Est. Total = \$18,150**

**Pots (# of pots) x \$600**  
 Area 1. 3 x \$600 = \$1,800  
 Area 2. 3 x \$600 = \$1,800  
 Area 3. 5 x \$600 = \$3,000

**3 Areas Est. Total = \$6,600**



**Potted Plant Container #2**  
 23" - \$600  
 40" - \$600  
 48" - \$600

**Potted Plant Container**  
 \$150 for EACH





Gumbo Pink Azalea



Confetti Spreading Lantana



Creeping Jenny Annual



Double Knockout Rose



Russian Sage Perennial



Pink Drift Rose



August Beauty Gardenia 'Frost Proof'



Purple Lantana



Golden Breath of Heaven



Marigold Annual



Vinca Annual



Wave Petunia



Landscape Planting w/o Edging ★



Potted Planter Container 1 ★



Potted Planter Container 2



Potted Planter Container 3 ★



Potted Planter Container 4



Potted Planter Container 5



Sea Green Juniper

March 2018

Oakmont PUD  
Planting



This drawing depicts conceptual landscape improvements for illustrative purposes. Final design solutions are subject to change.



## Legend

- 1 Custom Shade Structure
- 2 Insufficient Lighting. There is one light post. Playground needs more lighting
- 3 Existing Storm Drain
- 4 Existing Irrigation
- 5 Existing Trash Receptacle
- 6 Expansion
- 7 Walkway Bridge Connection

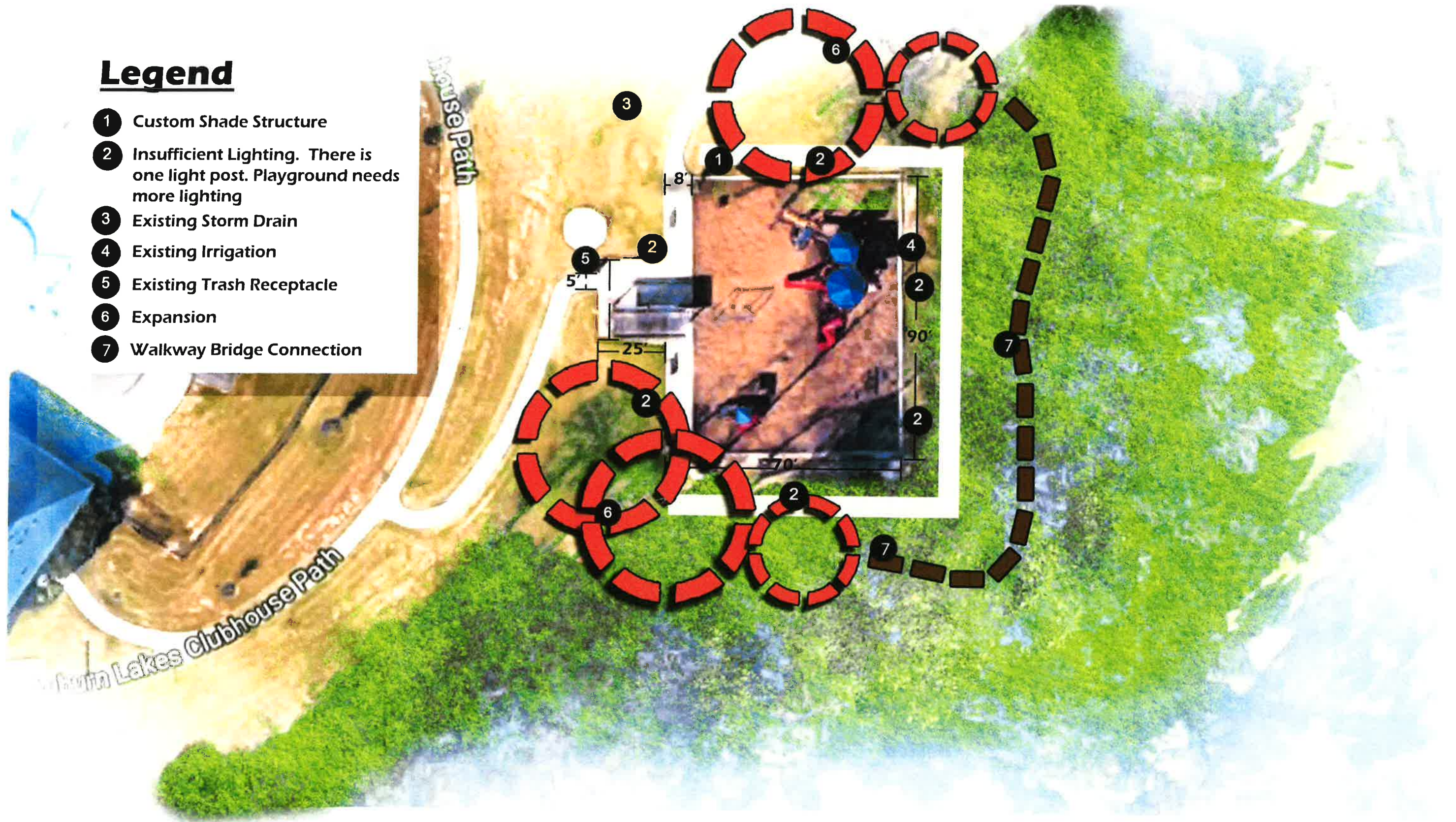

March 2018

Oakmont PUD  
Site Analysis for Playground



This drawing depicts conceptual landscape improvements for illustrative purposes. Final design solutions are subject to change.





March 2018

Oakmont PUD  
 Preliminary Idea Image Board - Playground Elements

MURR  
 LANDSCAPE ARCHITECTURE



This drawing depicts conceptual landscape improvements for illustrative purposes. Final design solutions are subject to change.



1:00 pm

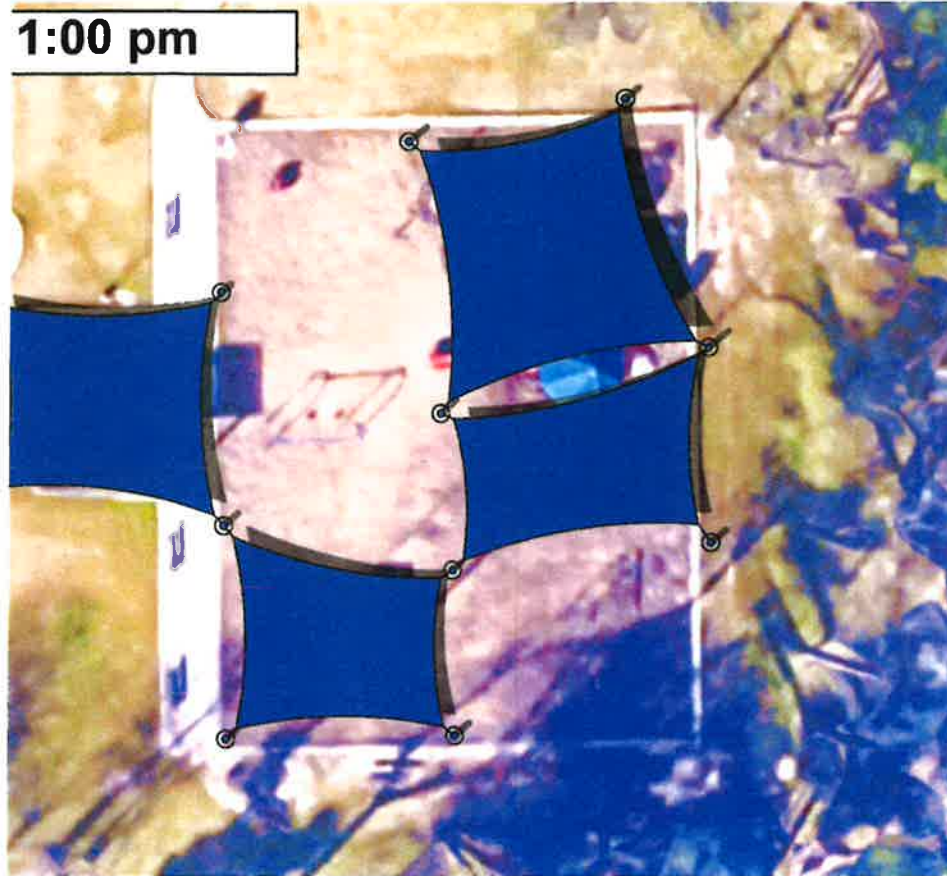

7/1 - 3:00 pm

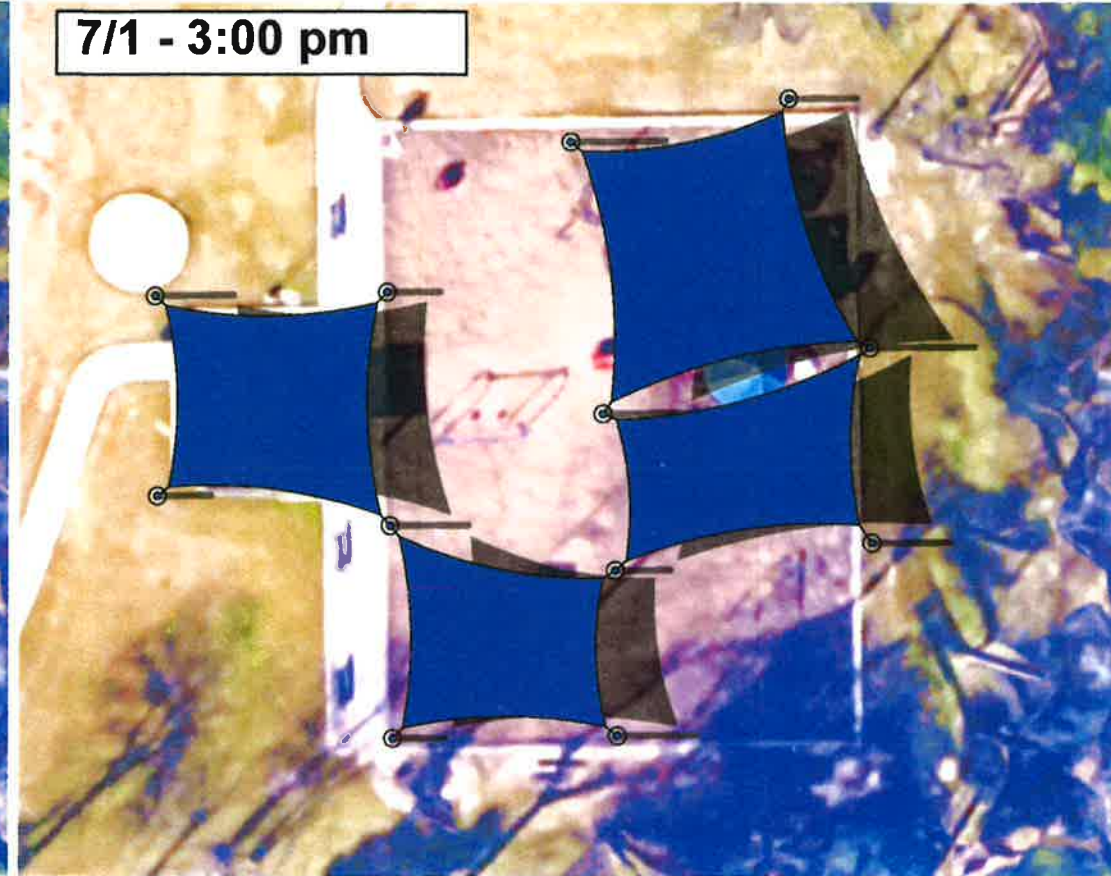

7/1 - 4:00 pm

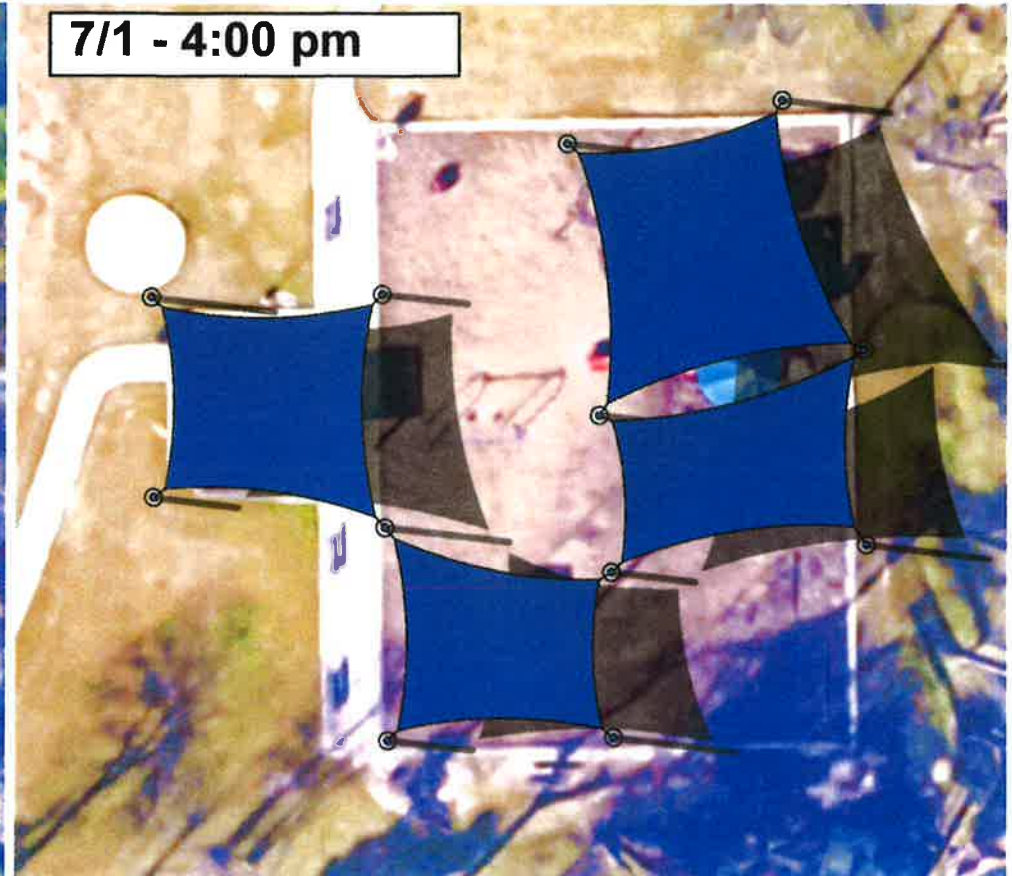

1:00 pm

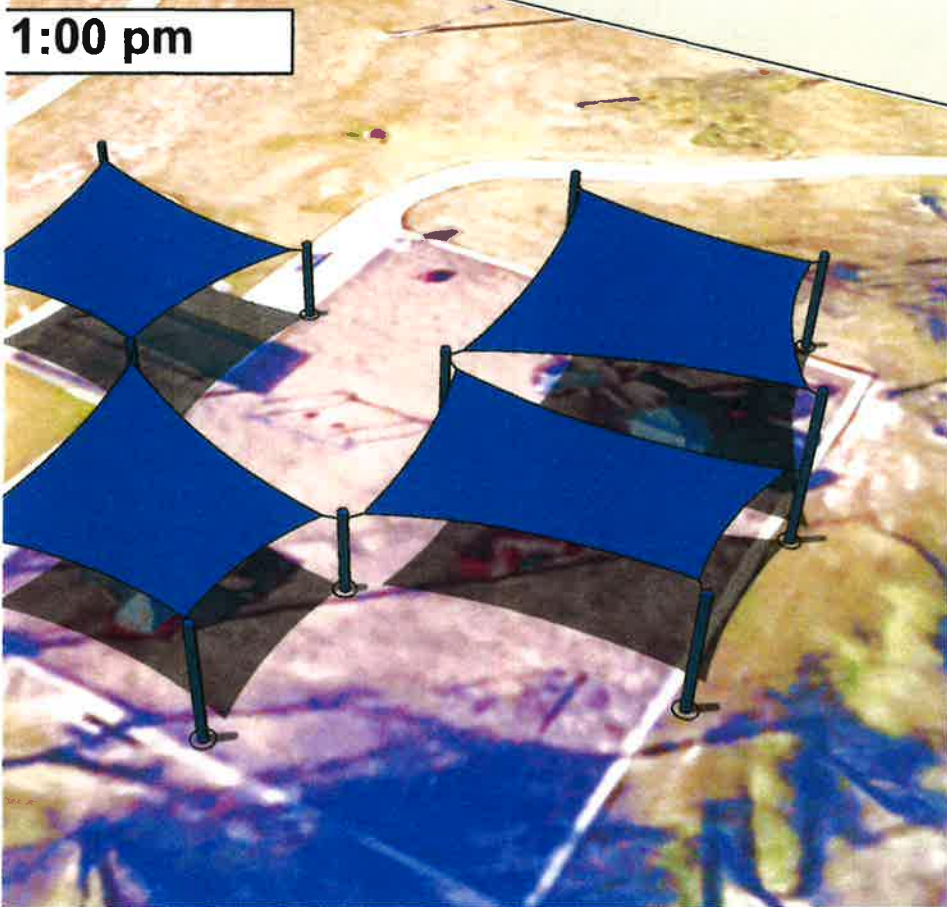

7/1 - 3:00 pm

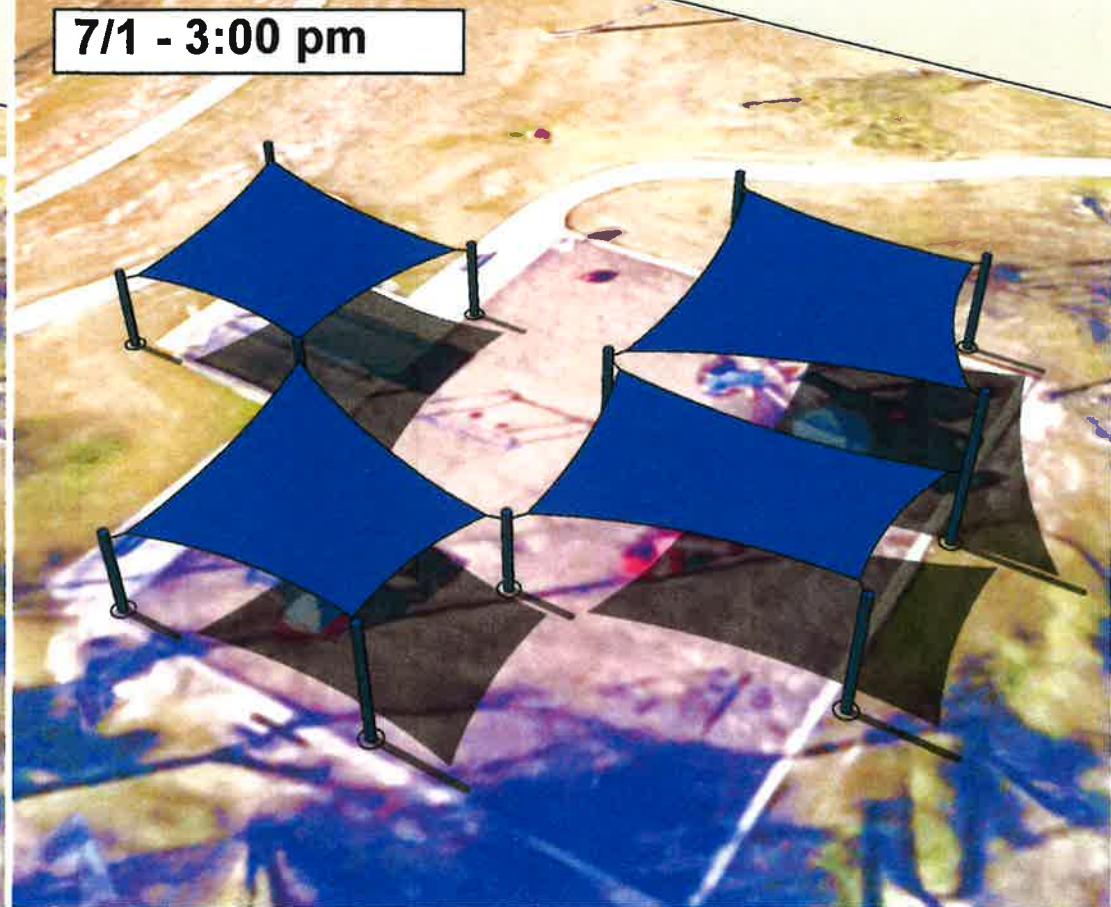

7/1 - 4:00 pm

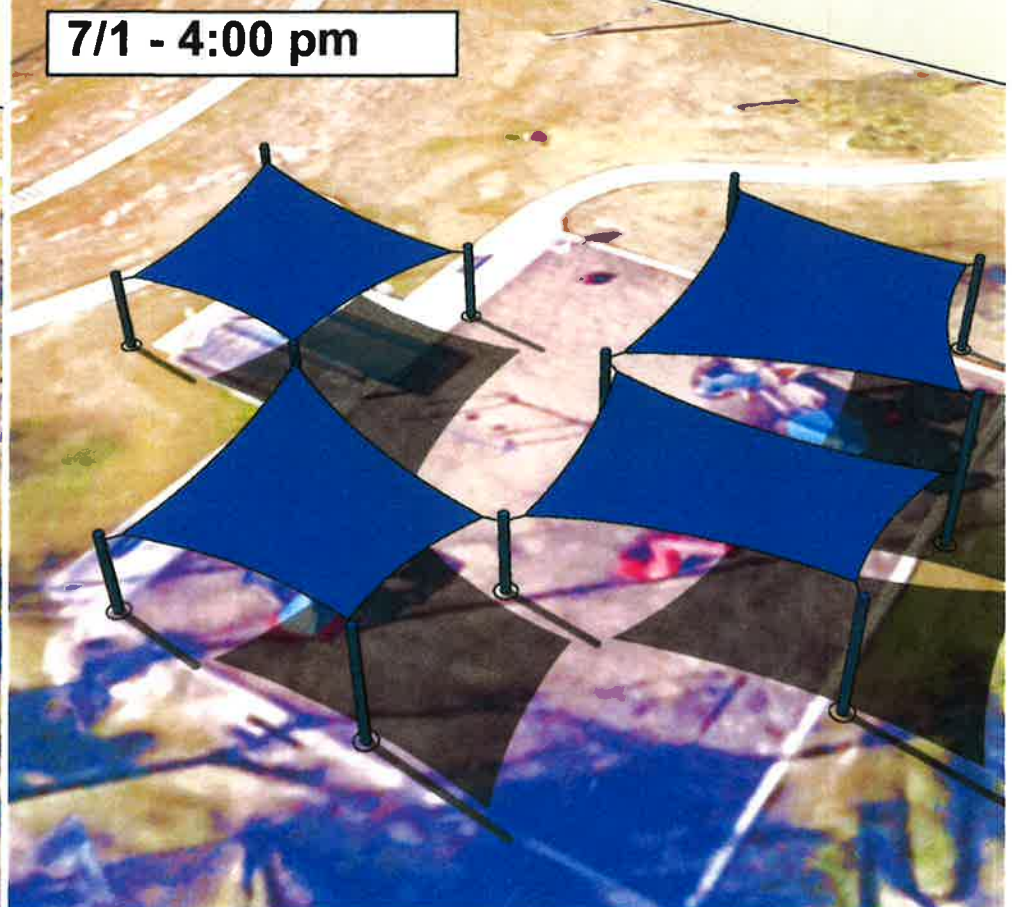



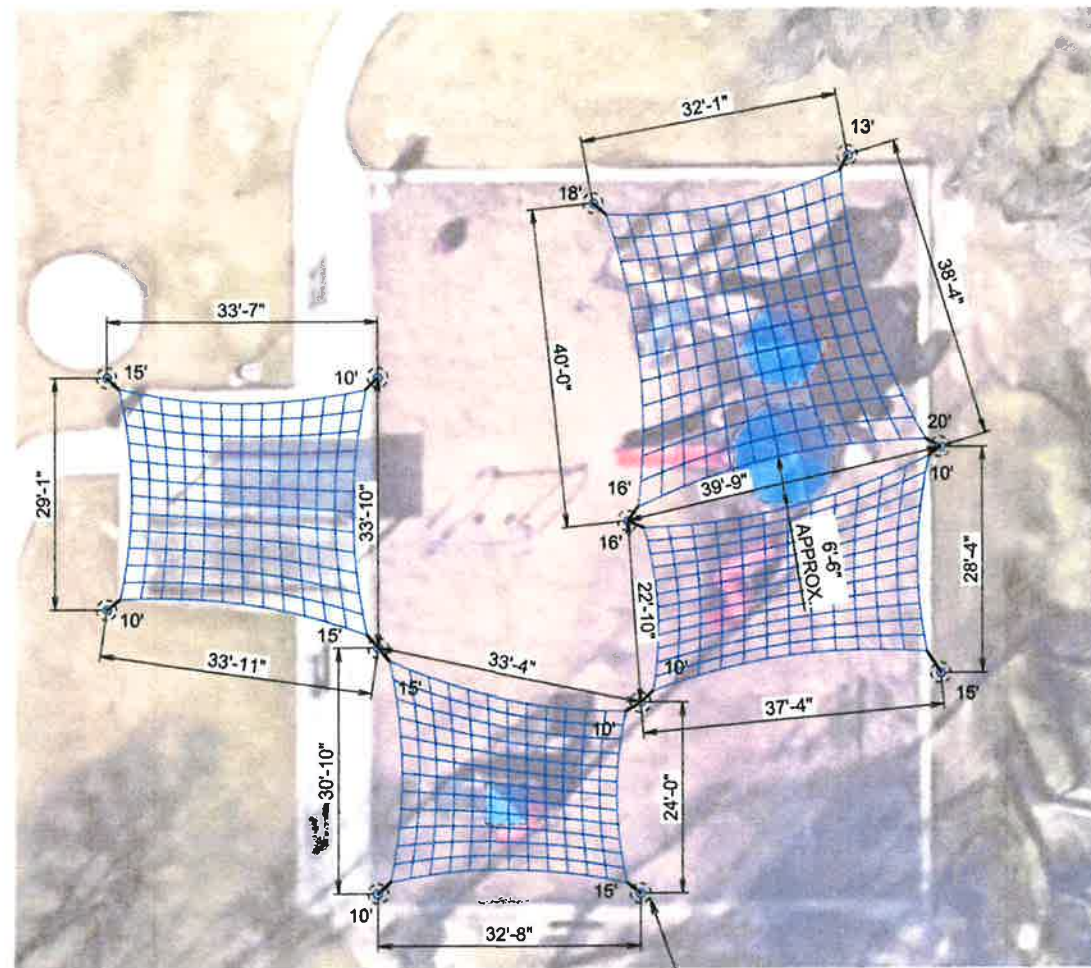

APPROX EDGE OF FOOTING (V.I.F.)

PLAN VIEW

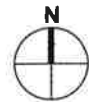

NOTES:  
 -THESE DRAWINGS ARE A PICTORIAL REPRESENTATION OF FABRIC AND STEEL ONLY. NONE OF THE REQUIRED ATTACHMENT OR CONNECTION DETAILS HAVE BEEN DEPICTED.  
 -ALL DIMENSIONS AND HEIGHTS MUST BE FIELD VERIFIED PRIOR TO ANY FINAL DESIGN, FABRICATION OR INSTALLATION WORK.  
 -FINAL FOOTING TYPE AND SIZE WILL BE DETERMINED AT ENGINEERING PHASE.

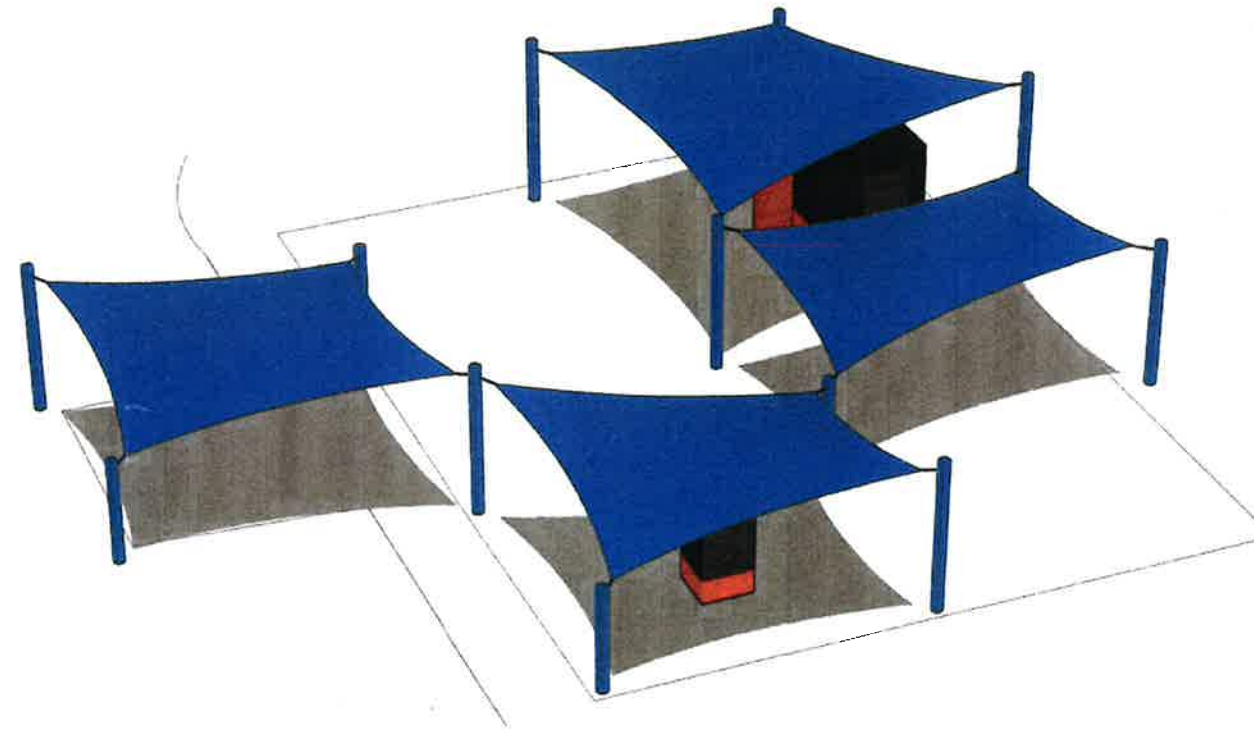

PERSPECTIVE VIEW

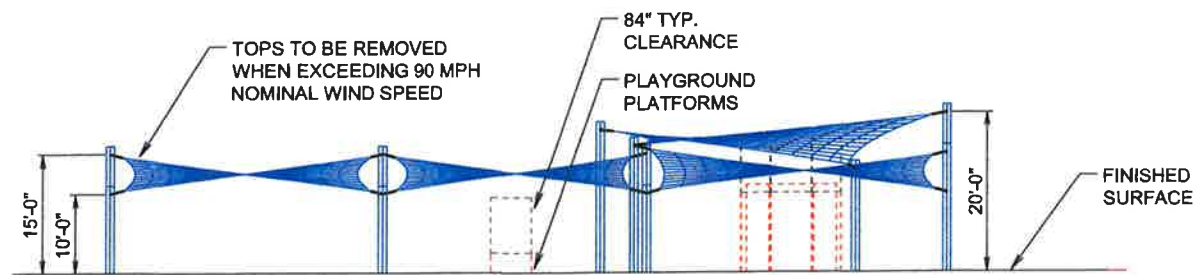

SOUTH ELEVATION

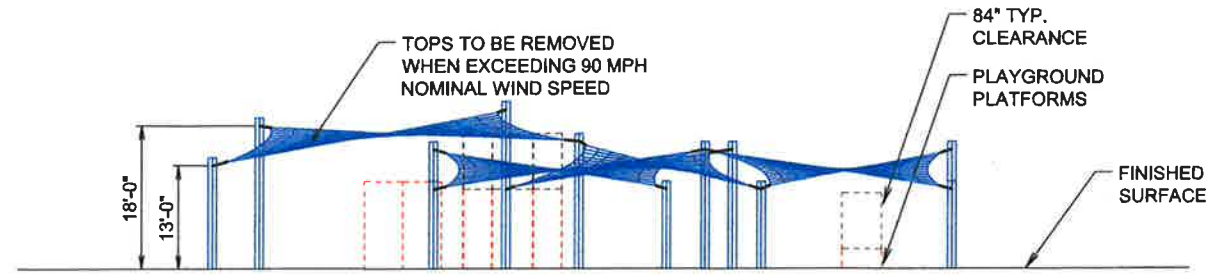

WEST ELEVATION

CUSTOMER:  
**MURR INC.**

PROJECT NAME:  
**OAKMONT PUD  
 PLAYGROUND SHADE**

LOCATION:  
**25005 NORTHCREST DR  
 SPRING, TX 77389**

STRUCTURE TYPE:  
**SAILS**

SIZE:  
**VARIES**

THESE PLANS AND SPECIFICATIONS ARE THE PROPERTY OF  
 USA SHADE AND FABRIC STRUCTURES  
 AND SHALL NOT BE REPRODUCED WITHOUT THEIR WRITTEN PERMISSION.

**USASHADE**  
 A Fabric Structures®

CORPORATE HEADQUARTERS  
 8505-A CHANCELLOR FROW  
 DALLAS, TX, 75247  
 800-966-5005

CERTIFICATIONS:  
 IAS CERTIFICATION No: FA-428  
 CLARK COUNTY MANUFACTURER  
 CERTIFICATION NUMBER (NEVADA): 355

REV	DESCRIPTION	DATE	DRW	CHK	ENG

Drawn By : YH 03/27/18  
 Checked By : YH 03/27/18  
 Approved By : YH 03/27/18

DRAWING DESCRIPTION:  
**VIEWS**

DWG.  
**CON-MAR-021-18**

PAGE  
**1000**

REV.

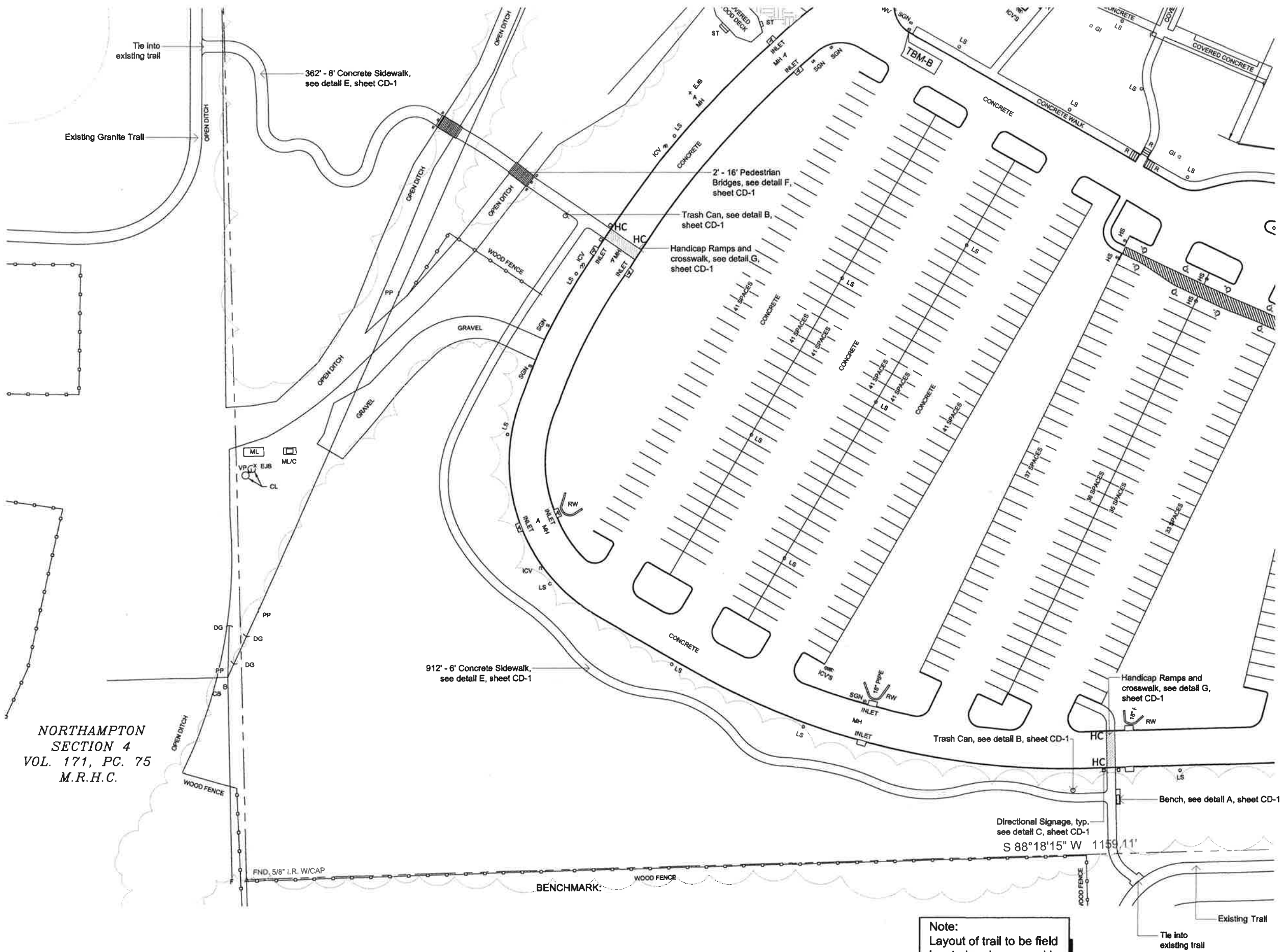

NORTHAMPTON  
SECTION 4  
VOL. 171, PG. 75  
M.R.H.C.

**Note:**  
Layout of trail to be field  
located and approved by  
Landscape Consultant



1803 GRANT RD. STE. 108  
CYPRESS, TX. 77429  
PH: 281.257.3375  
FAX: 281.376.4833  
www.murr-inc.com

Issue	Date
Issue for review	02/06/18

THIS PLAN IS NOT COMPLETE AND IS NOT INTENDED FOR BIDDING, CONSTRUCTION, OR PERMIT PURPOSES.

**WOODSEGE CHURCH  
TRAIL PROJECT**

Project No: WEC-01312018  
Drawn By: JEK

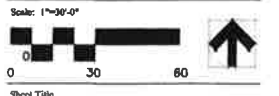

Sheet Title  
**Hardscape Plan**

Sheet Number:  
**LC-1**